



EPDM Closed Cell Elastomeric Foam Insulation

HVAC | VRF | Chilled Water | Refrigeration
Duct Wrap | Duct Liner | Plumbing

Aeroflex USA AEROFLEX EPDM™ Insulation

Installation Guide



www.aeroflexusa.com





AEROFLEX®

INTENT

The intent of the Aeroflex USA Installation Guide is to provide building/facility owners, mechanical engineers, design-build mechanical, and insulation contractors with illustrated step-by-step instructions and best practices for correctly installing the AEROFLEX® brand of EPDM closed cell flexible elastomeric foam insulation.

Although specific application methods are referenced in this guide, such as fabricating a variety of insulation fittings, there can be alternative installation methods to achieve a successful outcome with many applications. This guide does not address every method.

For additional industry references related to the installation of flexible closed cell elastomeric insulation, Aeroflex USA recommends considering the guidance of the following industry standards and installation specifications:

ASTM International (ASTM)

C1710 "Standard Guide for Installation of Flexible Closed Cell Preformed Insulation in Tube and Sheet Form"

<https://www.astm.org/Standards/C1710.htm>

National Insulation Association (NIA)

<https://insulation.org>

National Institute of Building Sciences (NIBS) | National Insulation Association (NIA)

"Mechanical Insulation Design Guide" (MIDG)

<https://www.wbdg.org/guides-specifications/mechanical-insulation-design-guide>

Midwest Insulation Contractors Association (MICA)

"National Commercial & Industrial Insulation Standards"

<https://www.micainsulation.org/standards-manual.html>

Sheet Metal & Air Conditioning Contractor's National Association (SMACNA)

"HVAC Duct Construction Standards - Metal & Flexible"

<https://www.smacna.org>

Manufacturers Standardization Society of the Valve and Fittings Industry (MSS)

"MSS SP-58, Pipe Hangers and Supports; Materials, Design, Manufacture, Selection, Application, and Installation"

<https://msshq.org>

INTRODUCTION

AEROFLEX EPDM™ is available in the following formulas:

- **AEROFLEX[®] Black**
- **AEROFLEX[®] White/Gray**

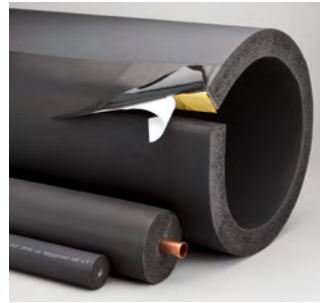

AEROFLEX Self-Seal™ Pipe Insulation

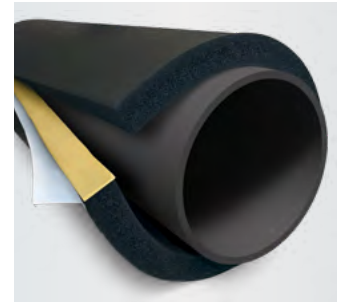

AEROFLEX Self-Seal LDP™ Pipe Insulation

*Aeroflex USA manufactures the **AEROFLEX[®]** brand of EPDM closed cell elastomeric foam insulation in Sweetwater, TN. **AEROFLEX[®]** complies with Buy American Act requirements.*

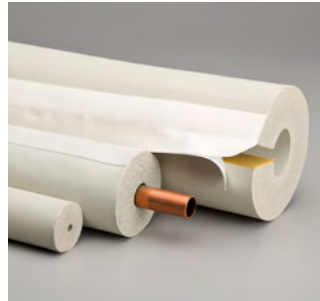

AEROFLEX White/Gray Tube Insulation

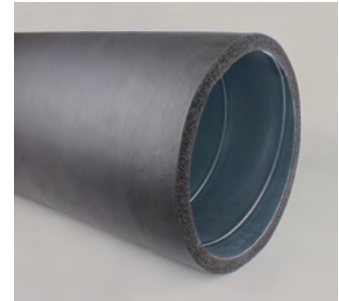

AEROFLEX Breathe-EZ[®] Duct Insulation

AEROFLEX EPDM™ is available in the following *formats*:

- Tubes (unslit - Black, White/Gray)
- Tubes (pre-slit, **Self-Seal™** & **Self-Seal LDP™** Black, White/Gray)
- Tubes (**Continuous Tube, Coil Pack**)
- Duct (**Breathe-EZ[®]**, **Breathe-EZ[®] PSA**)
- Sheets (**Sheet, Sheet w/PSA**)
- Rolls (**Roll, Roll w/PSA**)
- **AeroFit™** Factory fabricated insulation fittings (standard and mechanical-grooved available in Black and White/Gray)



AEROFLEX Breathe-EZ[®] Duct Liner



AEROFLEX EPDM™ Unslit Tube Insulation



AEROFLEX EPDM™ Continuous Tube Insulation

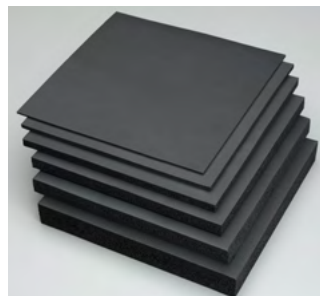

AEROFLEX EPDM™ Sheet Insulation

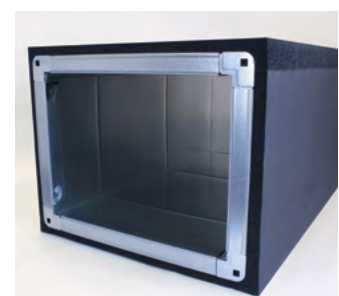

AEROFLEX Breathe-EZ[®] Duct Wrap



AEROFLEX EPDM™ Roll Insulation



AEROFLEX EPDM™ Roll w/ PSA Insulation



AEROFLEX AeroFit™ Insulation Fittings



AEROFLEX AeroFit™ Mechanical Grooved Insulation Fittings

AEROFLEX® installation system accessories include:

- **Adhesives**
 - **Cel-Link II®** glueless seam seals
 - **Aeroseal** (all applications)
 - **Aeroseal LVOC™ Black** (low-VOC, LEED compliant)
 - **REF 1520™** (all applications)
- **Protape®** EPDM high-performance zero-perm rubber tape
- **Aerotape™** EPDM foam tape
- **Aerofix®** insulated pipe supports
- **Aerocoat®** premium UV-protective coating
- **Aerocoat LVOC®** low-VOC UV-protective coating (LEED compliant)

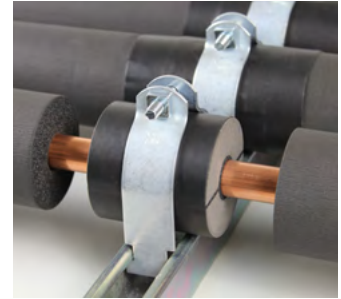

AEROFLEX Aerofix® Insulated Pipe Supports



AEROFLEX Aeroseal Adhesive



AEROFLEX Aeroseal LVOC™ Black Adhesive



AEROFLEX REF 1520™ Adhesive



AEROFLEX Protape® EPDM Seam Tape

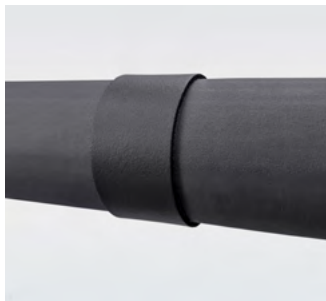

AEROFLEX Aerotape™ Foam Tape

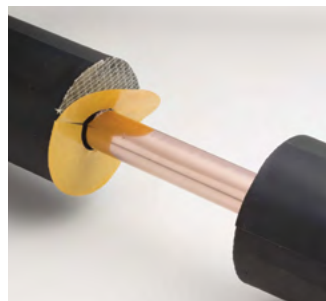

AEROFLEX Cel-Link II® Glueless Seam Seals



AEROFLEX Aerocoat® Insulation Coating



AEROFLEX Aerocoat LVOC® Insulation Coating

Key Compliances:

ASTM C534 Grade 1, Type I & II	ANSI/ASHRAE/IES 90.1
ASTM C1534, Type I	International Energy Conservation Code® (IECC®)
ASTM C692	California Title 24
ASTM D1056, 2C1	California Department of Public Health CDPH 01350
ASTM D1171	USGBC LEED®
ASTM E84, UL723, CAN/ULC-S102	EPA
NFPA 90A/90B	RoHS 3
ASTM E96	REACH
ASTM G21	Free of CFC's, HFC's, HCFC's, PBDE's & Nitrosamine
ASTM G7	Asbestos, formaldehyde & fiber-free
International Mechanical Code® (IMC®)	Buy American Act
International Residential Code® (IRC®)	MSS SP-58

TABLE OF CONTENTS

GENERAL INFORMATION

Definitions	6
Symbols	6
Tools	6
Best Practices	7
Substrate Preparation	7
AEROFLEX EPDM Insulation	7
Cel-Link II Glueless Seam Seals	9
AEROFLEX Adhesives	10
AeroFit Insulation Fittings	10
Aerofix Insulated Pipe Supports	11
Protape Aertape	12
Aerocoat Aerocoat LVOC	12
Sleeving Multi-Layering	12
AEROFLEX Sheet & Roll Pipes	13
Stainless Steel Piping	13
Exterior Applications	14
Cladding Jacketing	14
Direct Burial Underground	14
Heat Trace Systems	14
Maintenance Repair Replacement	15

SMALL DIAMETER PIPES

Unslit AEROFLEX tubes	16
Pre-slit AEROFLEX Self-Seal tubes	18
AeroFit Factory Fabricated Insulation Fittings	20
Using the AEROFLEX Template Field-Fabricated Fittings	20
Pipe Bends 45° angle Elbows	20
Pipe Bends 90° angle	21
Elbows (welded)	21
Elbows (oversized)	23
Curved Pipe Bends [$< 90^\circ$] Elbows (segmented)	24
Curved Pipe Bends [$> 90^\circ$] Elbows (oversized)	24
Pipe Intersections	25
T's	25
Angle-T's	27
Y-Tubes	28
Pipe Reducers	29
Valves	30

LARGE DIAMETER PIPES | ROUND SPIRAL DUCTS

AEROFLEX Sheet & Roll	<u>32</u>
Pipe Bends.....	<u>35</u>
Pipe Intersections	<u>39</u>
Collars Reducers	<u>40</u>
Flanges.....	<u>43</u>
Valves.....	<u>45</u>
Angled Valves	<u>49</u>
Pumps	<u>52</u>
Couplings.....	<u>52</u>

PIPE SUPPORTS

Pipe Hangers.....	<u>53</u>
Struts with Clamps.....	<u>54</u>
Struts Pipe Stands with Saddles/Shields.....	<u>55</u>
Vertical Riser Clamps	<u>56</u>
Other pipe support types	<u>57</u>

TANKS & VESSELS 58

DUCT WRAP | RECTANGULAR | ROUND SPIRAL 62

DUCT LINER | RECTANGULAR | ROUND SPIRAL 67

TECHNICAL RESOURCES

Nesting chart IPS.....	<u>72</u>
Nesting chart Copper	<u>73</u>
Stretch-out chart	<u>74</u>
Jacketing OD chart	<u>75</u>
Yield chart AEROFLEX Sheet & Roll.....	<u>76</u>
Aeroflex USA technical bulletins.....	<u>77</u>
Insulation thickness calculator	<u>77</u>
Aeroflex USA Express Limited Warranty	<u>78</u>

DEFINITIONS

Reference: ASTM C1710 Standard Guide for Installation of Flexible Closed Cell Preformed Insulation in Tube and Sheet Form (license agreement)

- **Seams** - longitudinal or horizontal cross-sections where insulation meets and must be adhered to itself or other system components.
- **Butt Joints** - cross-sections where two pieces of tubular or sheet insulation must be adhered to itself or other system components.
- **Vapor (Water) Stops** - locations/methods to prevent water or water vapor from traveling from one pipe insulation section to an adjacent insulation and prevent water traveling down annular space between the pipe insulation and the tubular pipe.
- **Sleeving/Multi-Layering** - applying another layer of insulation over the first layer. This process is used when the insulation thickness required is greater than that which is commercially available. This technique is also employed when proper installation practice requires multiple layers and or staggered joint application, even if a single layer thickness is available.

SYMBOLS



Direction/Application



Measurement



Measurement/Dimension

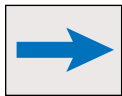

Section to be glued

TOOLS

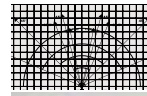

Template (printed on every AEROFLEX tube carton)



Tape measures (rigid & flexible)



Straight edge



Chalk (to mark measurements and cuts)



Ink marking pen (silver or light color)



Caliper (to measure outside diameters)



Divider (to draw reference lines)



Scissors



Denatured alcohol (to clean insulation and substrates)



Acetone (to clean tools)



Short knives (3", 7.6 cm)



Long knives (10", 25.4 cm)



Knife sharpener or stone



Sharp pipe ends (to make holes for common pipe sizes)



AEROFLEX squeegee (one included in every Self-Seal carton)



Brushes (short firm bristles to apply adhesives, standard for coatings)



Roller(s) to apply adhesives and coatings on flat surfaces



Gluemaster

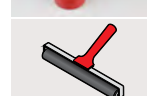

Weighted roller

BEST PRACTICES

Substrate Preparation

- **Never insulate a system in operation.** Turn off system 24 hours prior to installation to avoid moisture development under insulation, potential corrosion under insulation (CUI) and adhesive failure. Follow AEROFLEX adhesive complete dry times prior to system start-up.
- **Clean substrates** with denatured alcohol. Remove dirt, dust, grease, moisture, oil and other contaminants that can serve as corrosion accelerators beneath the insulation and bond-breaking agents on direct-adhered adhesive applications.
- **Untreated steel surfaces** must be treated with a rust inhibitor for HVAC/R applications. Follow the rust inhibitor manufacturer's full cure time prior to installing AEROFLEX.
- **Corrosion Protection Primers:** test AEROFLEX adhesive for compatibility with epoxy resin and polyurethane primers. Adhesives are not compatible with asphalt, bitumen, linseed oil or red lead primers.
- **Recommended application temperature** range (substrates and ambient) is 40°F - 100°F [4°C - 38°C].
- **Cold weather installation:** cold substrates will prolong flash time of adhesives. When conditions are below 40°F [4°C], adhesive bonded to very cold substrates may not flash off at all due to formation of condensation from latent heat of adhesive. Adhesive container can be warmed in a bucket of hot water. Adhesive container opening should be covered with a AEROFLEX sheet insulation or cardboard cut-out with brush hole to prevent adhesive from thickening. Stir frequently to prevent activators from settling to bottom.
- **Hot weather installation:** heated substrates will cause adhesive to flash off very quickly. If adhesive is left open beyond flash time, adhesion will not occur. Adjust by applying adhesive to smaller areas. Adhesive container opening should be covered with a AEROFLEX sheet insulation or cardboard cut-out with brush hole to prevent

adhesive from thickening. Stir frequently to prevent activators from settling to bottom.

Note: Do not use adhesives when relative humidity is 100% due to the formation of condensation on substrates.

AEROFLEX EPDM™ Insulation

1. **Storage:** store AEROFLEX insulation at 50°F - 85°F [10°C - 29°C], < 50% RH prior to installation. Cold closed cell elastomeric foam insulation will lose its flexibility. Keep dry.
2. **Pressure-Sensitive Adhesive (PSA):** Self-Seal tubes, Cel-Link II, Sheet & Roll with PSA, Breathe-EZ PSA, Protape and Aerotape should be installed when substrate and ambient temperatures are above 50°F [10°C]. At temperatures between 0°F - 50°F [4°C - 10°C], significant pressure must be applied to achieve an adequate bond. Installation of PSA products below 40°F [4°C] is not recommended. Pinch corner and pull release liner back 6" - 10" [15 cm - 25 cm] at a time during installation. For sheets/rolls, use weighted roller to achieve complete contact.

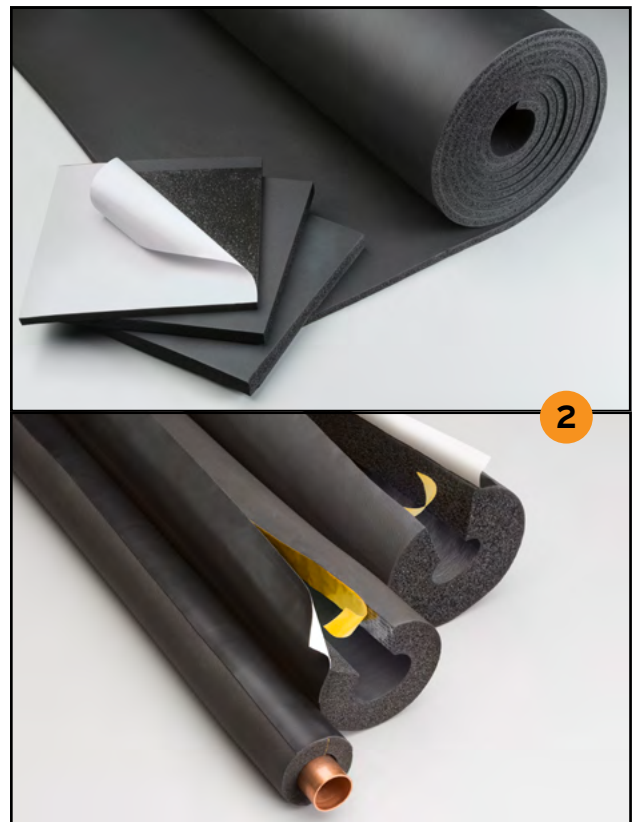

3. Sizing: properly sized pipe insulation tubes should slide easily over the pipe and fittings. AEROFLEX ID's are designed to properly fit copper and iron piping. A tube that fits loosely over a pipe is better than a smaller size that is too snug. Never stretch AEROFLEX insulation. An air gap between the pipe and insulation (annular space) is acceptable provided that all seams are completely sealed with an AEROFLEX adhesive. When measuring sheet material, mark where the adjoining edges overlap.

Note: Although AEROFLEX Self-Seal tubes are available up to 16" IPS, Sheet & Roll can be used on pipe sizes <4" [10 cm] OD.

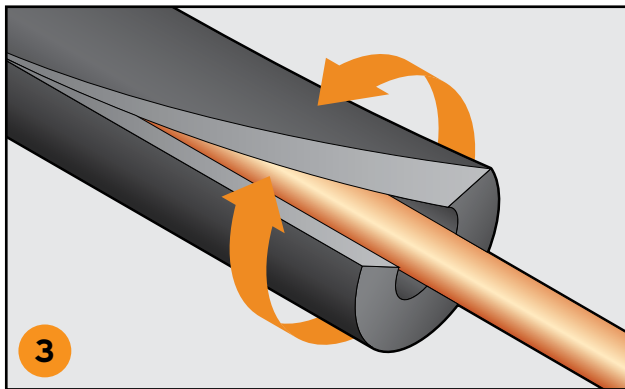

4. Cutting: use sharp non-serrated knives. Knife should be maintained at low angle to prevent tip from cutting/splitting inside wall. Cut flattest side of tube. Measure and cut all lengths (tube and sheet) long +1/8" [.32 cm] on each side (1/4", .64 cm) to install under compression. Use sharpened pipe cut-offs for holes. Glued seams should never be stretched and under stress.

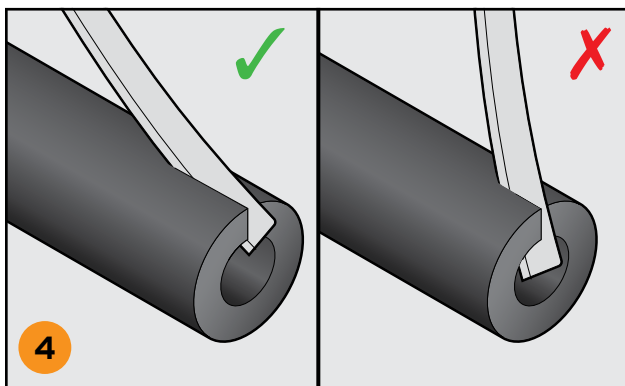

5. Push, Never Pull (Stretch) Insulation

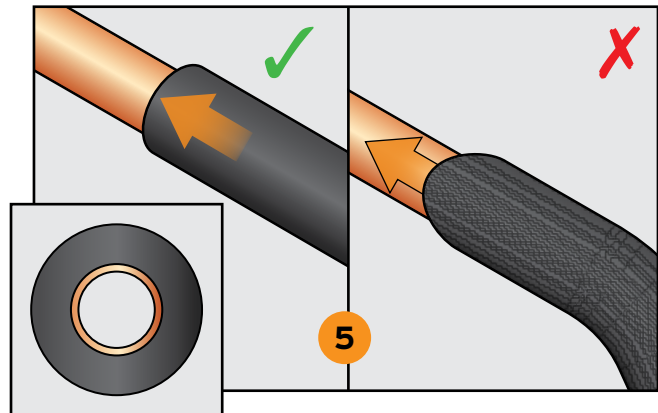

6. Spacing: allow a minimum of 4" [10 cm] between insulated chilled water and refrigeration pipes to allow for air movement to prevent condensation.

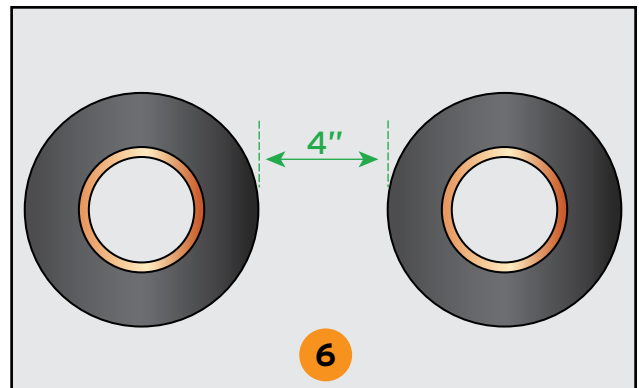

7. Seams, Butt Joints & Termination Points:

completely seal with AEROFLEX adhesive to create vapor seal in order to prevent air and moisture from penetrating under the insulation and causing corrosion under insulation (CUI). Seal all cut-outs and termination points, such as flanges,

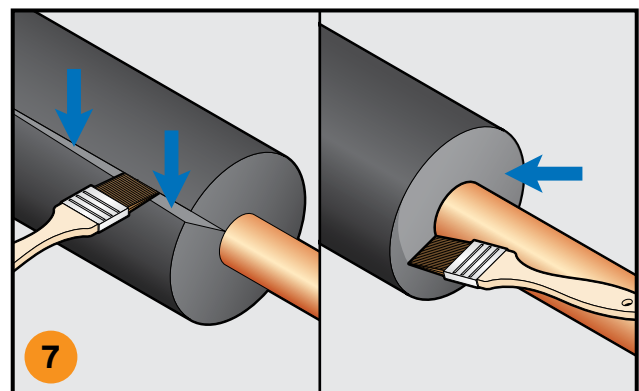

supports and valves, with AEROFLEX adhesive.

Note: Never use zip ties as substitute for adhesive; zip ties do not seal and they compress the insulation.

- 8. Vapor Stops:** for below-ambient (cold) applications, adhere the tube or sheet insulation directly to the pipe a maximum of every 18 linear feet [5.5 m]. The adhesive width should be at a minimum equal to the insulation thickness. Protape wrapped around the pipe can be used as vapor stop in place of adhesive. Seal butt joints with AEROFLEX adhesive or Cel-Link II for Self-Seal installations.

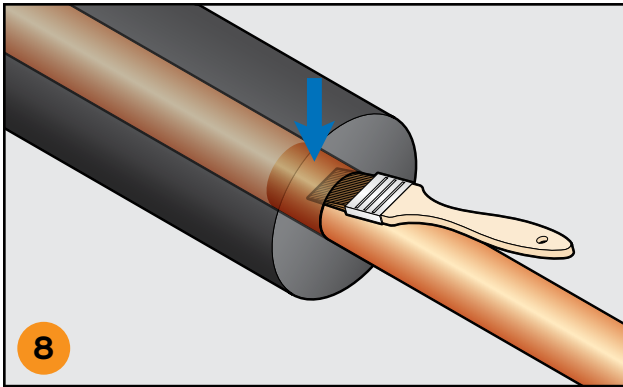

- 9. Taping Seams:** applying zero-perm Protape over sealed seams for interior applications is recommended as an additional level of protection to prevent CUI. For pipe sizes over 6" IPS [15 cm] and sheets/rolls over 1" thick [2.5 cm], apply 2" [5 cm] Protape evenly over seams followed by 2" on either side of taped seam (4" [10 cm] total taped seam width). Protape may be applied immediately over glued seams if AeroSeal or AeroSeal LVOC Black adhesive

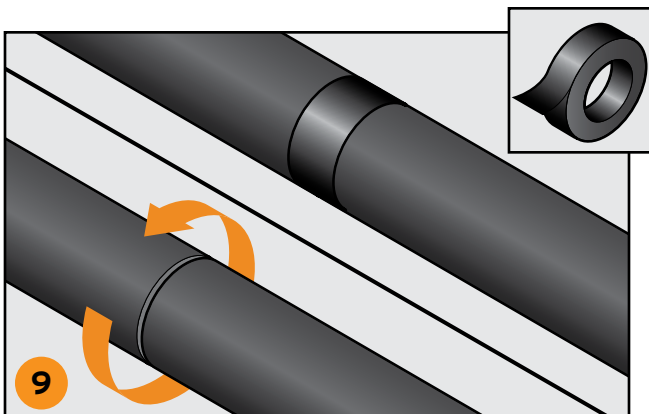

was dry to the touch prior to contact. For exterior applications, taping all glued seams with Protape is required; turn taped longitudinal seams away from direct sun exposure when possible.

- **Note:** Protape should never be installed over a seam that is not sealed with an AEROFLEX adhesive or Cel-Link II.

Cel-Link II® Glueless Seam Seals

- Install Cel-Link II over pipe and between adjoining tubes.
- Peel seam seal from release liner.
- Apply exposed adhesive side of Cel-Link II to one tube and thoroughly compress to maximize adhesion.
- Peel gold release liner to other side of seam seal facing adjoining tube and align longitudinal seams.
- Press adjoining tubes together under compression.
- Apply 2" Protape evenly over all butt joints (required).

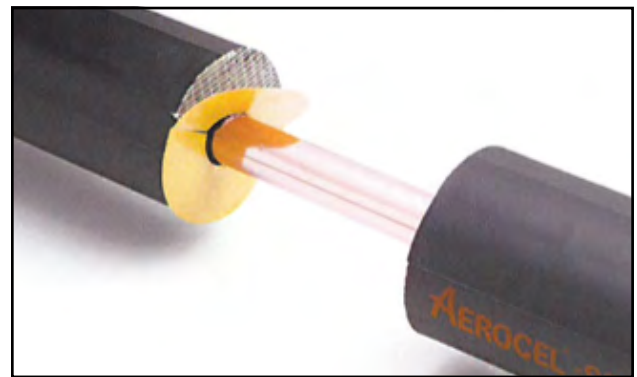

AEROFLEX® Adhesives



- Read label and follow warnings; work area should be well-ventilated; do not smoke.
- Do not thin adhesives.
- Substrates, ambient temperatures and adhesive should be 40°F - 100°F [4°C - 38°C].
- Do not use below 40°F [4°C].
- Store at 60°F - 80°F [16°C - 27°C].
- Do not allow to freeze.
- Cold adhesive containers can be warmed in bucket of hot water.
- Stir thoroughly before use and frequently during use.
- For non-brush top containers, use a Gluemaster or cover opening with AEROFLEX sheet insulation or cardboard cut-out with brush hole to prevent adhesive from thickening.
- Follow tack time on label and adjust based on jobsite conditions - ambient temperature, relative humidity and wind.
- **Aeroseal and Aeroseal LVOC Black adhesives must be dry to the touch (no transfer) prior to contact to ensure immediate adhesion and a permanent bond.**
- **REF 1520 adhesive must be tacky (no transfer) prior to contact to ensure a permanent bond.**
- **Aeroseal LVOC Black adhesive requires a longer tack time than Aeroseal or REF 1520; allow 3-5 minutes depending on ambient conditions during installation. LVOC adhesive must be dry to the touch (no transfer) prior to contact to ensure immediate adhesion and a permanent bond.**

TIP - Use the "fingernail test" to determine when tack time has been achieved; touch the glued surface with fingernail; if fingernail sticks and glue transfers, the adhesive is not ready; if the fingernail does not stick, there is no glue transfer and adhesive is either dry to the touch (Aeroseal and Aeroseal LVOC Black) or tacky (REF 1520), the two glued surfaces are ready for contact.

- Apply thin even coat to both surfaces to be sealed with a short stiff-bristle brush from the inside out (tubes) or with an adhesive/short-nap roller for sheets and rolls.
- Brush adhesive on approximately 7" [18 cm] on one surface, then 7" [18 cm] on the other surface, alternating back and forth until longitudinal seam is glued; once adhesive is ready for contact, press both surfaces together under compression to ensure full adhesion.
- Avoid stretching and tension at glued seams.
- When applying to surfaces other than insulation (i.e. metal termination points), apply adhesive to AEROFLEX insulation first, then the other surface.
- For applications over concrete substrates, consult with Aeroflex USA.
- For exterior applications, turn glued seams away from sun when possible.
- Use acetone to clean tools.

AeroFit™ EPDM Insulation Fittings



- AeroFit insulation fittings ship unslit.
- When fittings and straight runs are same size, install fittings first followed by straight sections.
- When fittings are larger than straight runs (oversized), install straight runs first.
- Slit inside radius of fitting (throat) with sharp knife.
- Install over pipe fitting to ensure proper fit - snug or slightly loose (not stretched).

- Apply adhesive to both sides of radius seam; allow to tack up and press together under compression to ensure full adhesion and vapor seal.
- When bonding insulation fittings to straight runs of pipe insulation, allow adhesive to tack up and press together under compression to ensure complete adhesion and vapor seal.
- Optional: for interior applications, apply Protape over glued seams.
- Required: for exterior applications, apply Protape over glued seams; turn taped longitudinal seams away from direct sun exposure when possible.

Aerofix® Insulated Pipe Supports

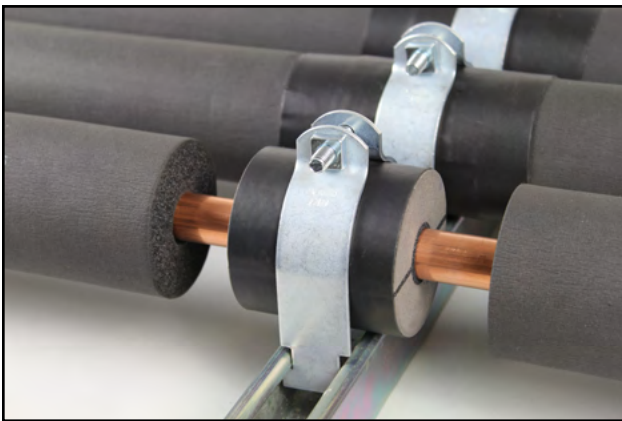

- Open Aerofix fitting, remove two inside release liners, wrap around pipe, center at hanger location and firmly press two halves together.
- Remove release liner from Protape outer jacket and apply with firm pressure to achieve a strong bond.
- Position Aerofix so seam between the two halves is horizontal to the legs of pipe support system.
- Do not allow any gaps in the closure of the insulation envelope.
- Seal Aerofix to adjoining AEROFLEX insulation tubes with AEROFLEX adhesive and press together under compression to ensure vapor seal.
- Optional: for systems operating above -20°F [-29°C], apply Protape over glued seams.
- Required: for systems operating below -20°F [-29°C], apply Protape over glued seams.
 - **NOTE:** for installations on strut channel hangers, refer to page 53.

Protape®



- Clean surfaces to receive Protape with denatured alcohol.
- Recommended substrate and ambient temperature should be above 50°F [10°C]. At temperatures between 40°F - 50°F [4°C - 10°C], significant pressure must be applied to achieve an adequate bond. Installation is not recommended below 40°F [4°C].
- If Aero seal or Aero seal LVOC Black adhesives were dry to the touch prior to contact, Protape may be applied over sealed seams immediately after insulation installation (seams and full coverage adhesion).
- If REF 1520 adhesive was tacky to the touch prior to contact, tape may be applied over sealed seams (24-36 hours) and full adhesive coverage (7 days) after insulation installation.
- Optional: for interior installations, apply Protape over glued seams.
- Required: For pipe sizes over 6" IPS and sheets/rolls over 1" thick, apply 2" Protape evenly over seams followed by 2" on either side of taped seam (4" [10 cm] total taped seam width).

Aerocoat® | Aerocoat LVOC®

- Select Aerocoat LVOC for LEED® registered projects.
- Recommended application temperature is 50°F - 100°F [10°C - 38°C]
- Ensure insulation surface is free from dust, grease, oil or moisture prior to application. Use denatured alcohol if necessary.
- Do not dilute or tint.
- No primer is required.
- If Aroseal or Aroseal LVOC Black adhesives were installed and dry to the touch prior to contact, coating may be applied immediately after insulation installation (seams and full coverage adhesion).
- If REF 1520 adhesive was installed and tacky to the touch prior to contact, coating may be applied over seams (24-36 hours) and full adhesive coverage (7 days) after insulation installation.
- Stir thoroughly and apply with new brush or short-nap roller.
- Two coats are required to achieve 100% coverage; allow a minimum of 4 hours between coats.
- Apply Aerocoat or Aerocoat LVOC within 2 weeks of installation for optimum UV protection.
- Clean-up: clean water.



- Sheet or Roll should be used as second layer when tube size is not available.
- Edges of second layer (tubes or sheets) should be adhered to first layer with AEROFLEX adhesive.
- 16" - 24" [41 cm - 61 cm] pipes: adhere bottom 3rd of first layer to pipe, or second layer to first layer, with AEROFLEX adhesive to prevent sagging.
- 24"+ [61 cm] pipes: full adhesion with AEROFLEX adhesive is required for all layers.

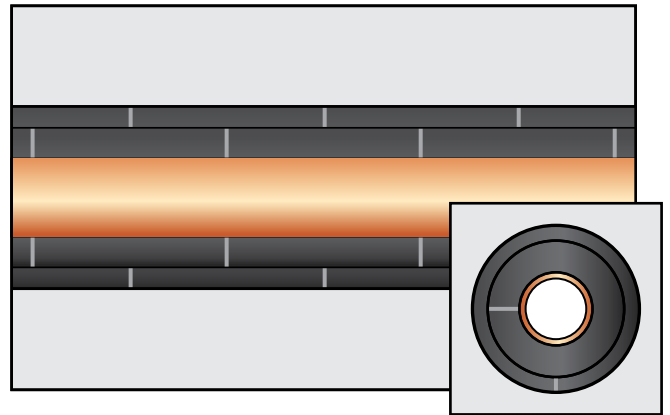

- Apply Protape over sealed seams for additional protection (required for exterior applications).
- **Reference:** aeroflexusa.com/technicalresources/technical-bulletins/december-2020.

- Flat Surfaces

- Stagger all seams of first and second layers.

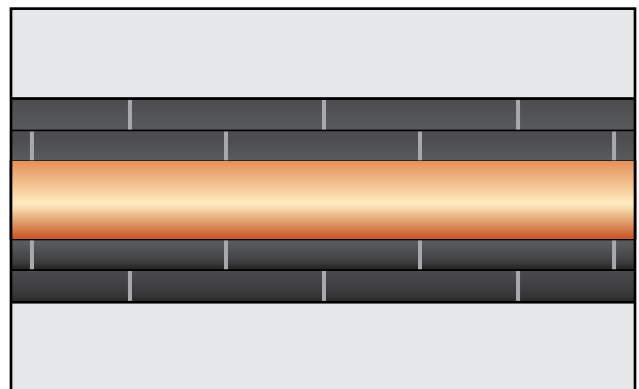

- First layer of AEROFLEX sheets to be installed with full AEROFLEX adhesive coverage or AEROFLEX with PSA (pressure-sensitive adhesive back).
- Adhere second layer to first layer with full coverage using AEROFLEX adhesive.
- Apply Protape over sealed seams for additional protection (required for exterior applications).

Sleeving | Nesting



- **Piping:**
 - Stagger and seal all longitudinal and transverse seams with AEROFLEX adhesive.

AEROFLEX® Sheet & Roll on Pipes



- To minimize waste of AEROFLEX Sheet & Roll, refer to [AEROFLEX Yield Table - Sheet & Roll](#).

Stainless Steel Piping



- AEROFLEX EPDM is safe for austenitic stainless-steel piping; AEROFLEX will not cause external stress crack corrosion (ESCC).
 - **Reference:** [aeroflexusa.com/technical/resources/technical-bulletins/february-2021](#).

Exterior Applications

- Although AEROFLEX EPDM has greater UV-resistance than traditional NBR/PVC closed cell flexible elastomeric insulation, UV protection is recommended to prolong the life of AEROFLEX. Options include Aerocoat, Aerocoat LVOC or an insulation jacketing system. When mechanical damage, such as impacts from maintenance, extreme weather, birds, etc. are expected,

AEROFLEX should be protected with a jacketing system.

- For pipe sizes over 6" IPS and sheets/rolls over 1" thick, apply 2" Protape evenly over seams followed by 2" on either side of taped seam (4" [10 cm] total taped seam width).



- **Note:** Aerocoat and Aerocoat LVOC satisfy national and state energy code requirements, such as ASHRAE 90.1, IECC® and California Title 24, for outdoor service protection from solar radiation (adhesive tape is not permitted).
- **Reference:** [aeroflexusa.com/technical/resources/technical-bulletins/july-2020](#).

Cladding | Jacketing



- Aeroflex USA does not recommend specific protective jacketing systems. However, the specified and installed system should be sized correctly so it does not compress the insulation. See "Cladding | Jacketing" schedule under Technical Resources for AEROFLEX pipe insulation OD's.
 - **Reference:** [aeroflexusa.com/technical/resources/technical-bulletins/september-2020](#).

Direct Burial | Underground



- AEROFLEX should be sleeved within a protective conduit, such as a fully-supported and sealed waste-water drainage pipe, to ensure long-term performance once backfilled.
- Direct contact with soil acids, ground water chemicals, contaminants, plus insulation compression from the weight of the backfilled soil, can reduce the thermal efficiency and life of the insulation.
- **Reference:** aeroflexusa.com/technical/resources/technical-bulletins/april-2020.

Heat Trace Systems



- AEROFLEX is compatible with self-regulating heat trace systems which ensure that the continuous line temperature does not exceed 257°F [125°C].
- For proper fit, the next tube ID size up should be installed.

- An air gap between the pipe and insulation (annular space) is acceptable provided that all seams are completely sealed with an AEROFLEX adhesive to create a vapor seal.
- **Reference:** aeroflexusa.com/technical/resources/technical-bulletins/august-2020.

Maintenance | Repair | Replacement

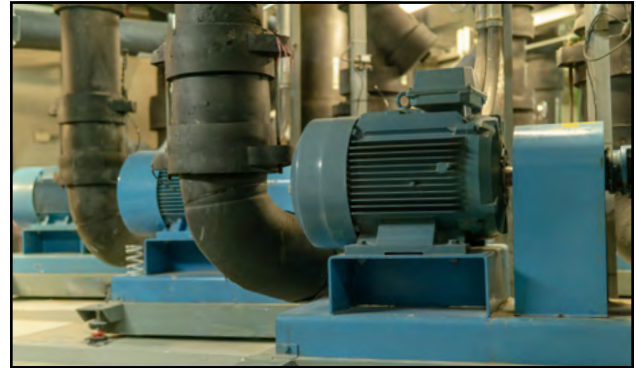

- **Maintenance**
 - For light-duty cleaning, use non-acidic neutral cleaner.
 - For heavy-duty cleaning, use denatured alcohol.
- **Repair**

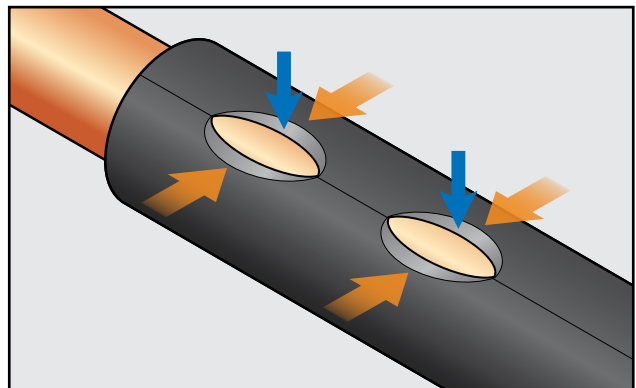

- Openings at longitudinal seams and butt joints
 - Apply AEROFLEX adhesive to existing edges and allow adhesive to tack up.
 - When ready for contact, apply firm pressure to both sides of seams to ensure complete adhesion and a vapor seal.
 - Apply Protape over sealed seams (optional for interior applications, required for exterior applications).

- Cuts/nicks to surface (skin)
 - Seal with AEROFLEX adhesive and apply Protape over sealed repair (optional for interior applications, required for exterior applications).

- **Replacement**

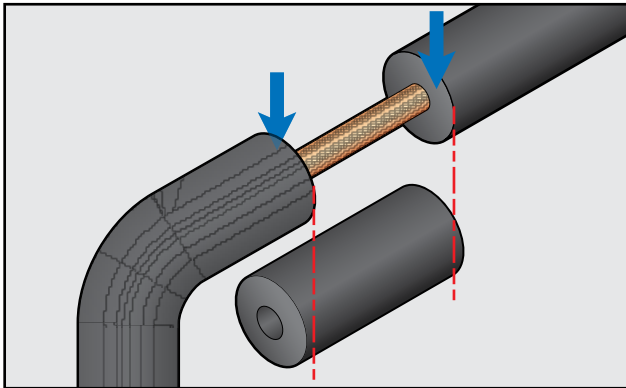

- Carefully cut out damaged section on pipe, duct or equipment with sharp non-serrated knife.
- For multi-layer applications, take care not to cut into 1st or 2nd layers; avoid cutting directly over sealed seams below to maintain staggered seam layout.
- Cut replacement piece of same AEROFLEX tube, sheet or roll insulation to fit under compression.
- Apply AEROFLEX adhesive to existing edges and replacement piece; allow adhesive to tack up.
- When ready for contact, carefully install replacement piece under compression without gaps.
- Ensure complete adhesion to create vapor seal.
- Apply Protape over sealed seams (optional for interior applications, required for exterior applications).

SMALL DIAMETER PIPES



- **Unslit AEROFLEX Tubes**



• **Slide-On Method (new uninstalled piping)**

- Push (never pull) tube over pipe.
 - **Note:** AEROFLEX unslit tube sizes up to 3-1/8" [7.9 cm] ID ship with an asbestos-free talc for ease of installation.
- Do not push tube over pipe bends when insulation thickness is 1/2" [1.3 cm] or greater.

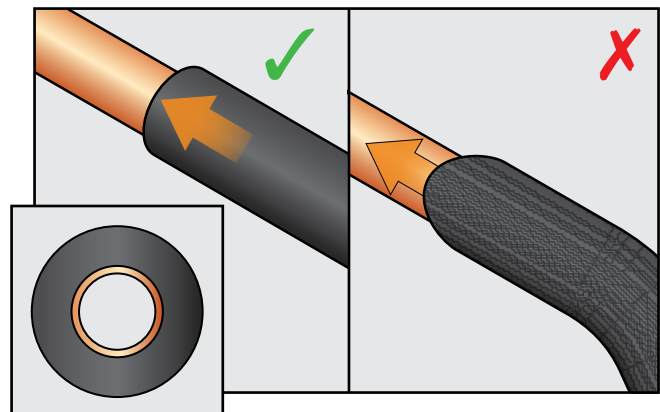

- Install AeroFit or field-fabricated mitered fittings at pipe bends to prevent insulation compression (reduced thickness) and condensation.

- Adhere insulation directly to the pipe with AEROFLEX adhesive a maximum of every 18' [5.5 m] to create a vapor stop on below-ambient (cold) systems. **BEST PRACTICES/AEROFLEX EPDM INSULATION/VAPOR STOPS.**
- Glue adjoining tubes and fittings with AEROFLEX adhesive following **BEST PRACTICES/AEROFLEX ADHESIVES.**
- Once adhesive is ready for contact, press both sides of glued butt joints together with firm pressure under compression to ensure complete adhesion.

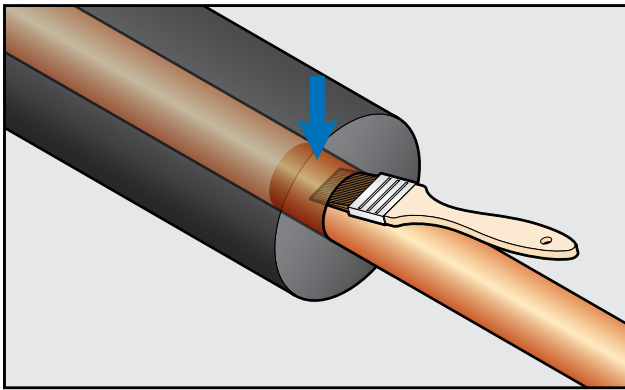

- Optional: for interior installations, apply Protape over glued butt joints and fittings.
- Required: for exterior installations, apply Protape over glued longitudinal seams, butt joints and fittings.
- Optional (recommended): to maximize AEROFLEX life cycle for exterior applications, apply Aerocoat, Aerocoat LVOC or jacketing system for UV protection. For mechanical protection, install jacketing system specifically designed for pipe insulation.

• **Snap-On Method (installed piping)**

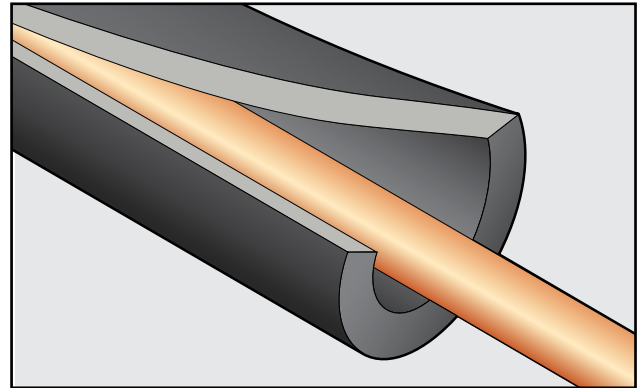

- Slit flattest side of tube along 6' [1.8 m] longitudinal seam with sharp non-serrated knife; maintain knife at low angle to prevent tip from cutting inside wall of tube.

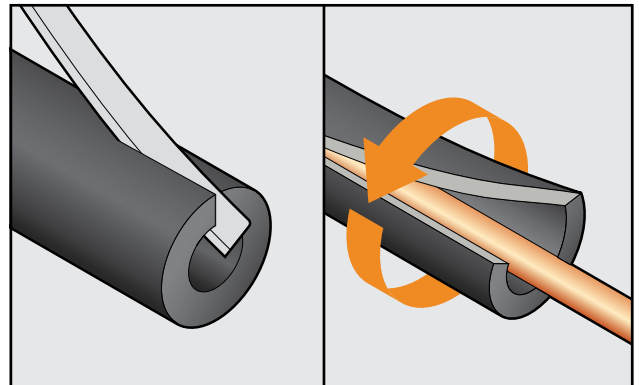

- Install mitered fittings at pipe bends to prevent insulation compression (reduced thickness) and condensation.
- **Notes:**
 - Welded pipes (pipe & fittings same size) - insulate fittings first.
 - Pipes with large fittings - insulate straight runs first.
- Snap slit tube over clean pipe.
- Adhere insulation directly to the pipe with AEROFLEX adhesive a minimum of every 18' [5.5 m] to create a vapor stop on below-ambient (cold) systems. **BEST PRACTICES/AEROFLEX EPDM INSULATION/VAPOR STOPS.**

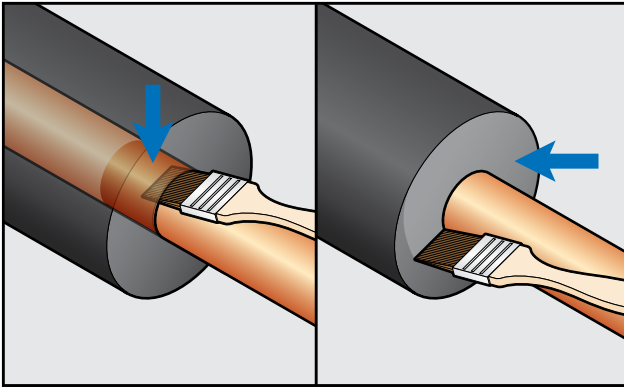

- Glue longitudinal seams, butt joints and fittings with AEROFLEX adhesive. **BEST PRACTICES/AEROFLEX ADHESIVES**

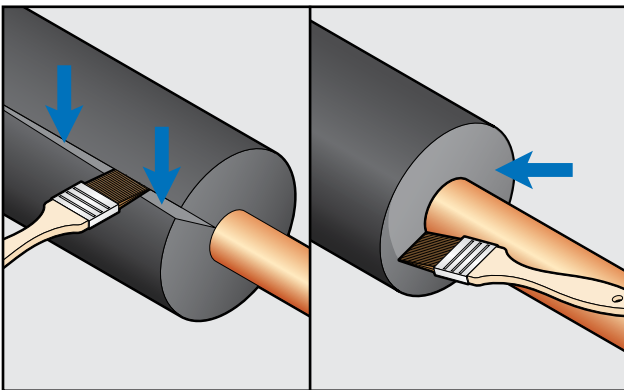

- Turn longitudinal seam down or out of sight line before adhering to butt joints and fittings with AEROFLEX adhesive.
- Once adhesive is ready for contact, press both sides of glued longitudinal seams and butt joints together under compression with firm pressure to ensure complete adhesion.

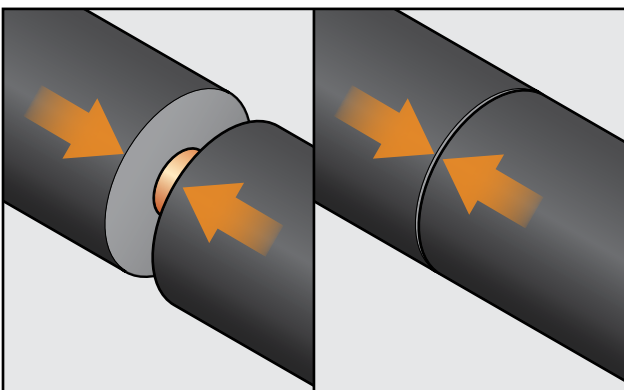

- Optional: for interior installations, apply Protape over glued longitudinal seams, butt joints and fittings.
- Required: for exterior installations, apply Protape over glued longitudinal seams, butt joints and fittings; turn taped longitudinal seams away from direct sun exposure when possible.
- Optional (recommended): to maximize AEROFLEX life cycle for exterior applications, apply Aerocoat, Aerocoat LVOC or jacketing system for UV protection. For mechanical protection, install jacketing system specifically designed for pipe insulation.

- Pre-slit AEROFLEX Self-Seal Tubes



- **CAUTION: BEST PRACTICES/AEROFLEX EPDM INSULATION/PRESSURE-SENSITIVE ADHESIVE (PSA)**
- Install mitered fittings at pipe bends to prevent insulation compression (reduced thickness) and condensation.
 - **Notes:**
 - Welded pipes (pipe & fittings same size) - insulate fittings first.
 - Pipes with large fittings - insulate straight runs first.

- Open Self Seal tube and snap on pipe.

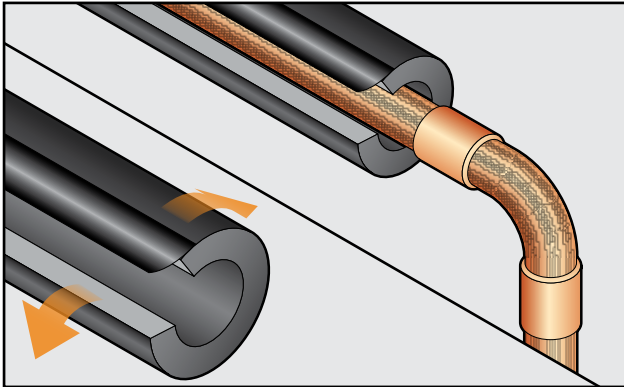

- Gently press Protape double closure seal away from inside seam before adhering inside walls together.
- Locate the end of gold release liner on inside wall and slowly pull away from tube approximately every 12" [30 cm].

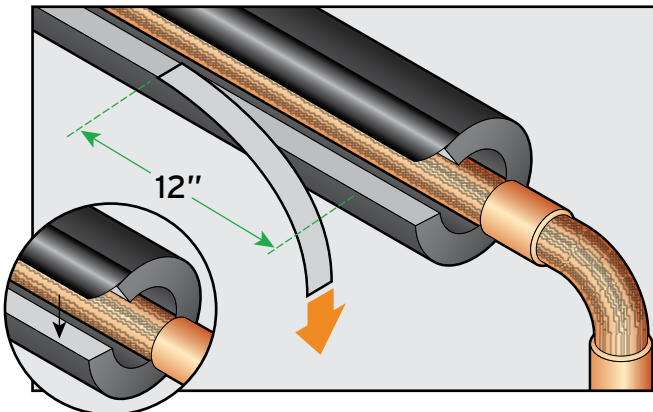

- Carefully line up and press approximately 12" [30 cm] PSA seam together with firm pressure to ensure complete adhesion.

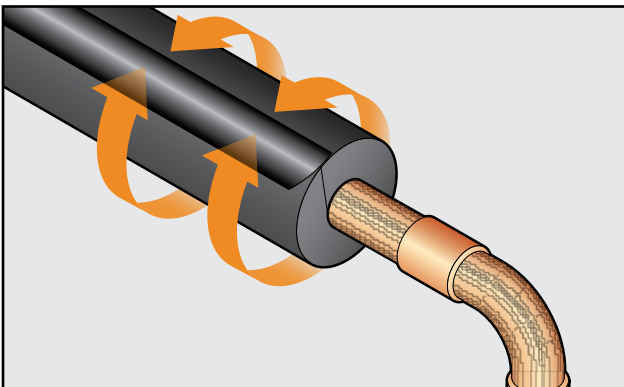

- Repeat until inside wall of Self Seal tube is completely sealed.
- If necessary, clean outside skin of tube where Protape will adhere to with denatured alcohol.
- Locate release liner to Protape double closure seal and slowly pull away.

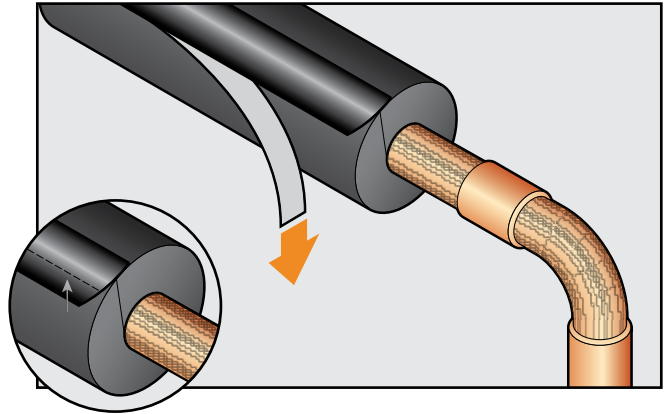

- Carefully press Protape double closure seal onto clean outside wall of tube with firm pressure, avoiding any kinks or gaps, until the Self Seal tube is fully sealed.

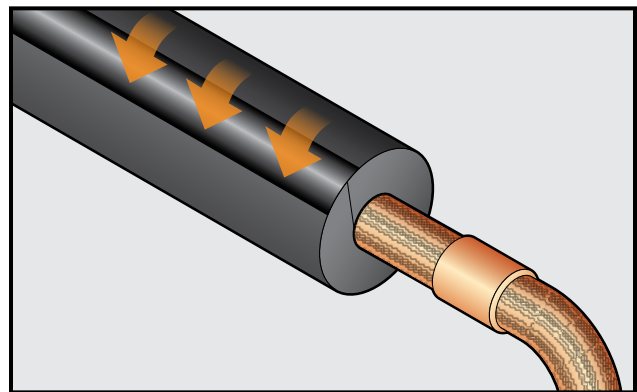

- Apply AEROFLEX squeegee (included in every carton of Self-Seal) to Protape seam seal to remove any air bubbles, kinks or gaps.
- Adhere insulation directly to the pipe with AEROFLEX adhesive a minimum of every 18' [5.5 m] to create a vapor stop on below-ambient (cold) systems. **[BEST PRACTICES/AEROFLEX EPDM INSULATION/VAPOR STOPS](#)**

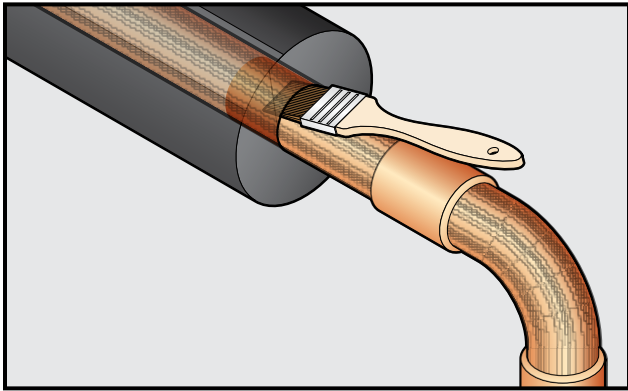

- Glue adjoining tubes and fittings with AEROFLEX adhesive following **BEST PRACTICES/AEROFLEX ADHESIVES**.

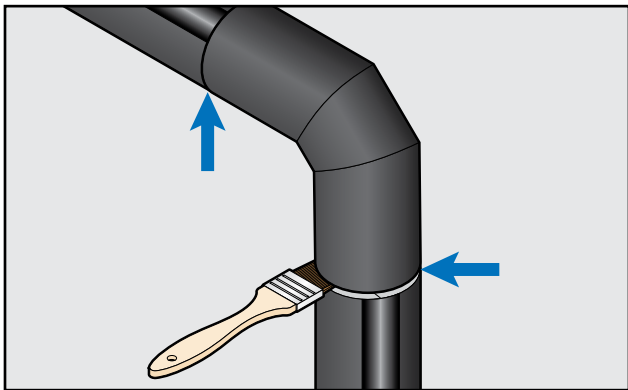

- Turn longitudinal seam down or out of line of sight before adhering to butt joints and fittings.
- Once adhesive is ready for contact, press glued butt joints together under compression with firm pressure to ensure complete adhesion of AEROFLEX adhesive.

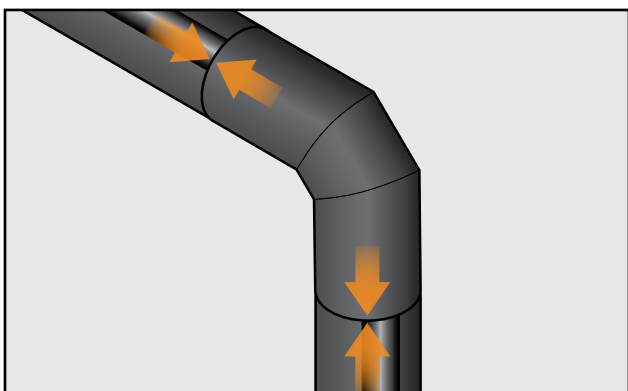

- Optional: for interior installations, apply Protape over glued butt joints and fittings.

- Required: for exterior installations, apply Protape over glued butt joints and fittings; turn taped longitudinal seams away from direct sun exposure when possible.
- Optional (recommended): to maximize AEROFLEX life cycle for exterior applications, apply Aerocoat, Aerocoat LVOC or jacketing system for UV protection. For mechanical protection, install jacketing system specifically designed for pipe insulation.

- AeroFit Factory Fabricated Insulation Fittings **BEST PRACTICES/AEROFIT INSULATION FITTINGS**



- Using the AEROFLEX Template | Field-Fabricated Fittings

- The AEROFLEX Template is printed on every carton of AEROFLEX pipe insulation as a convenient alternative to a miter box to fabricate quality fittings in the shop or field for the most common pipe fittings.

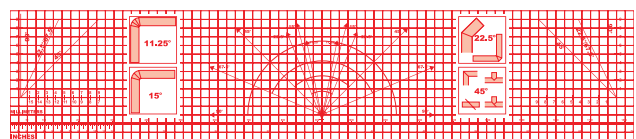

- Break down an empty carton or cut out template and place on flat work surface.
- Use a sharp non-serrated knife with a knife sharpener on hand.
- Place tube along bold horizontal base line.
- Mark cuts with light-colored marker or chalk.
- Align knife with desired angle reference and cut smoothly through tube; ensure clean cuts without rough edges. Sharpen knife if necessary.

- **Pipe Bends | 45° | 2-piece**
 - **Elbows - Welded** (fitting & piping same diameter)

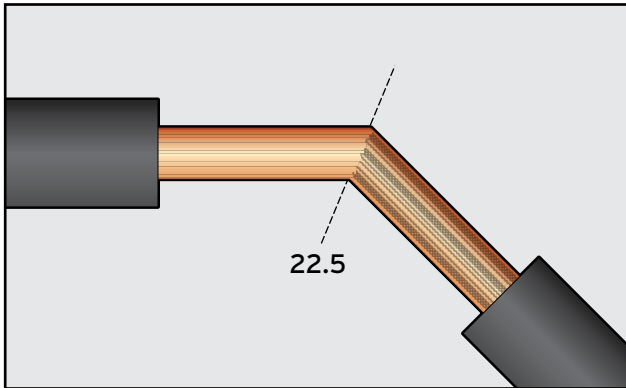

- Straight pipe runs are typically insulated up to 45° bend.

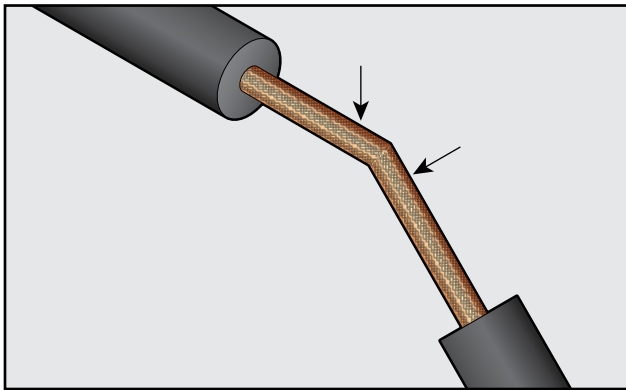

- Cut AEROFLEX unslit tube at 22.5° angle using AEROFLEX Template and long sharp knife.

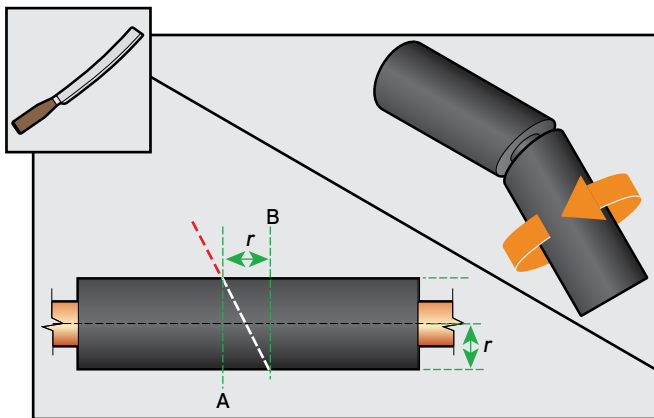

- Cut horizontal and vertical lengths long to install with compression to adjoining tubes.
- Glue two 22.5° pieces under compression to form 45° angle with AEROFLEX adhesive.

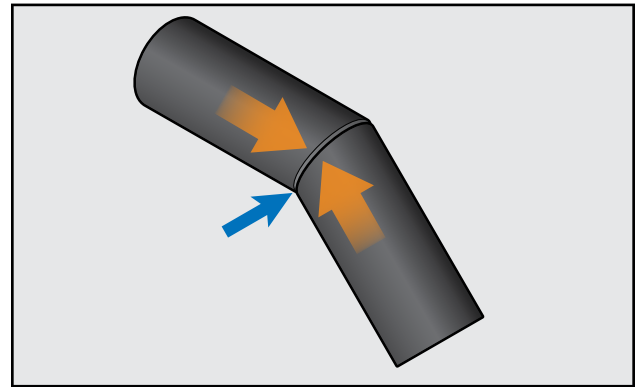

- Once 45° seam is bonded, cut inside radius of insulation fitting (throat).

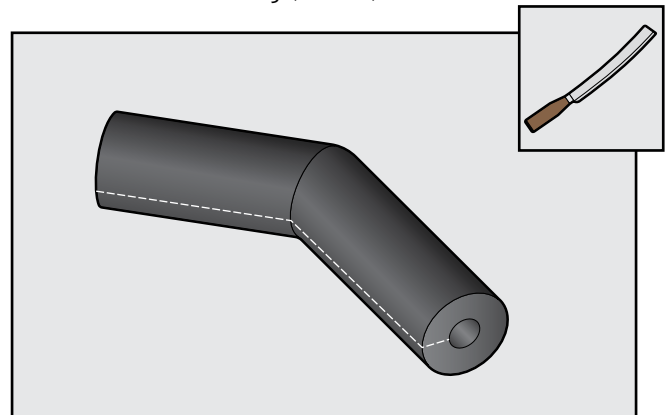

- Install over pipe fitting and glue throat under compression with AEROFLEX adhesive.
- Glue insulation fitting to adjoining tubes under compression with AEROFLEX adhesive.

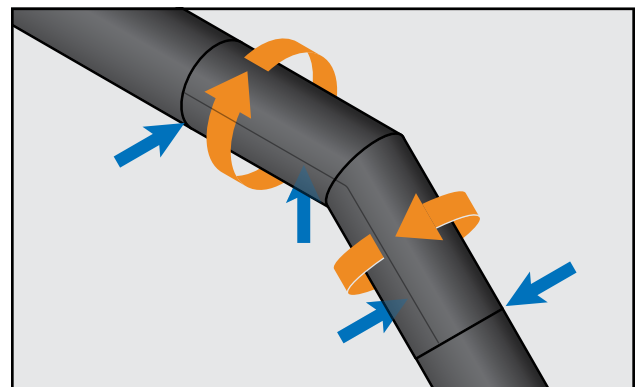

- Ensure complete vapor seal with no gaps present.
 - Optional: for interior installations, apply Protape over glued longitudinal seams, butt joints and fittings.

- Required: for exterior installations, apply Protape over glued longitudinal seams, butt joints and fittings; turn taped longitudinal seams away from direct sun exposure when possible.
- Optional (recommended): to maximize AEROFLEX life cycle for exterior applications, apply Aerocoat, Aerocoat LVOC or jacketing system for UV protection. For mechanical protection, install jacketing system specifically designed for pipe insulation.

- Pipe Bends | 90° | 2-piece

- **Elbows - Welded** (fitting & piping same diameter)

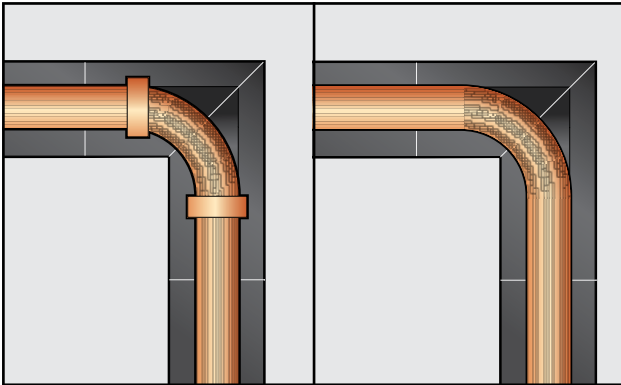

- Install insulation fitting before insulating straight runs.

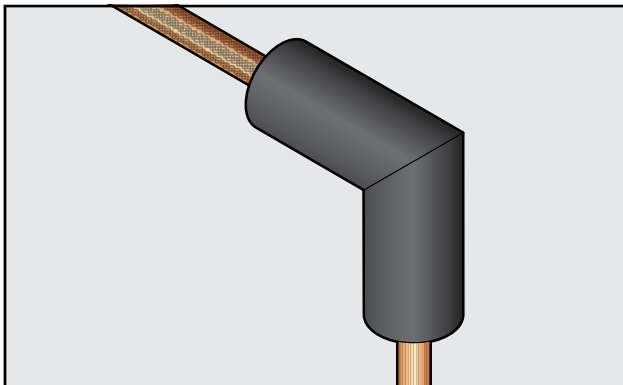

- **Note:** If straight runs are installed prior to 90° insulation fitting, measure and cut insulation fitting to fit with compression.

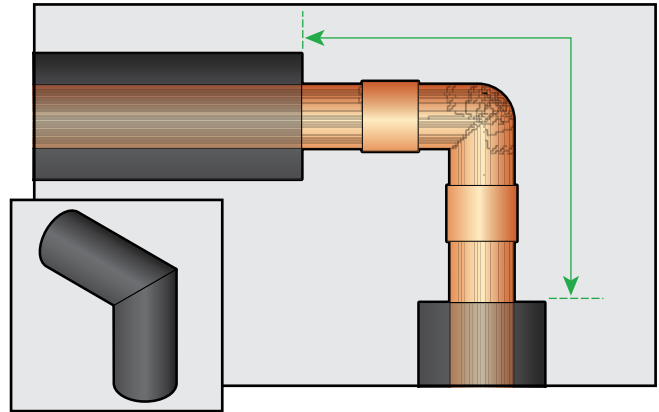

- Cut AEROFLEX unslit tube at 45° angle using Aeroflex Template and long sharp knife.

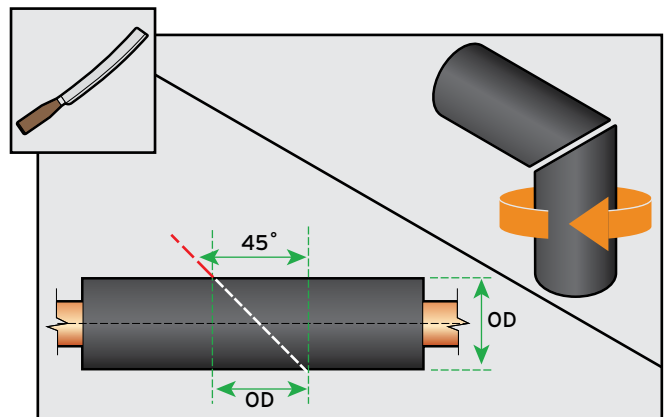

- Cut horizontal and vertical lengths long to install with compression to adjoining tubes.
- Glue two 45° pieces under compression to form 90° angle with AEROFLEX adhesive.

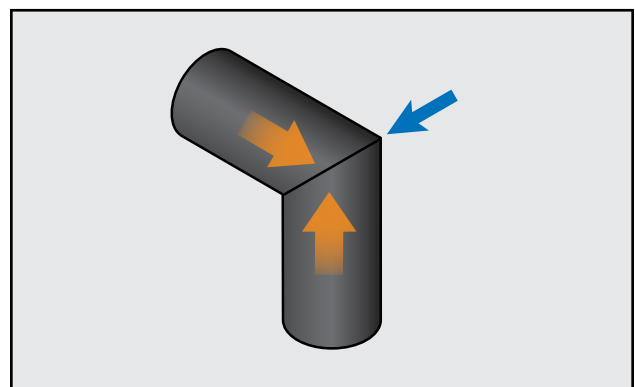

- Once 45° seam is bonded, cut inside radius of insulation fitting (throat).

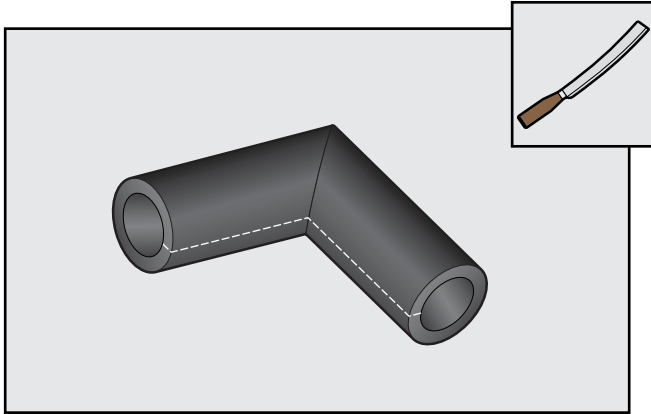

- Install over pipe fitting and glue throat under compression with AEROFLEX adhesive.

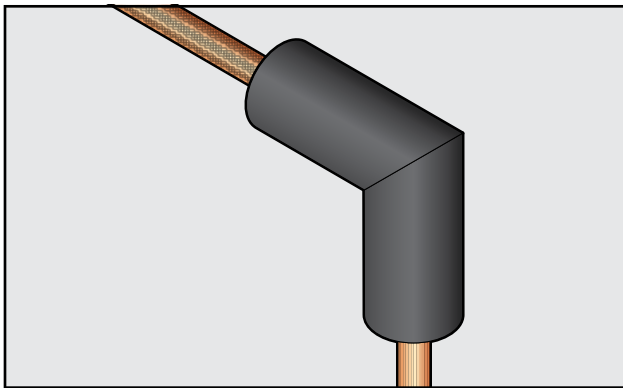

- Glue insulation fitting to adjoining tubes under compression with AEROFLEX adhesive.

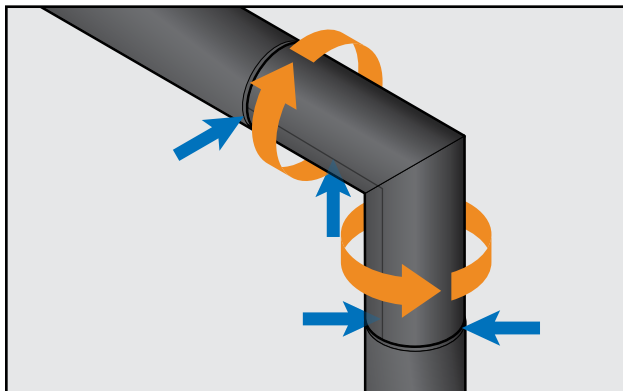

- Ensure complete vapor seal with no gaps present.
- Optional: for interior installations, apply Protape over glued longitudinal seams, butt joints and fittings.

- Required: for exterior installations, apply Protape over glued longitudinal seams, butt joints and fittings; turn taped longitudinal seams away from direct sun exposure when possible.
- Optional (recommended): to maximize AEROFLEX life cycle for exterior applications, apply Aerocoat, Aerocoat LVOC or jacketing system for UV protection. For mechanical protection, install jacketing system specifically designed for pipe insulation.

• **Elbows - Oversized** (fitting larger than piping)

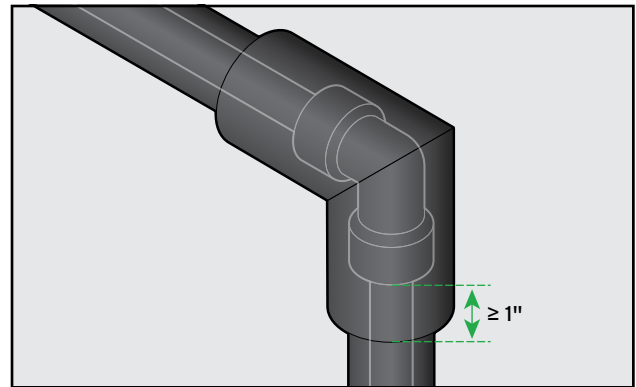

- Insulate straight runs before insulation fittings.

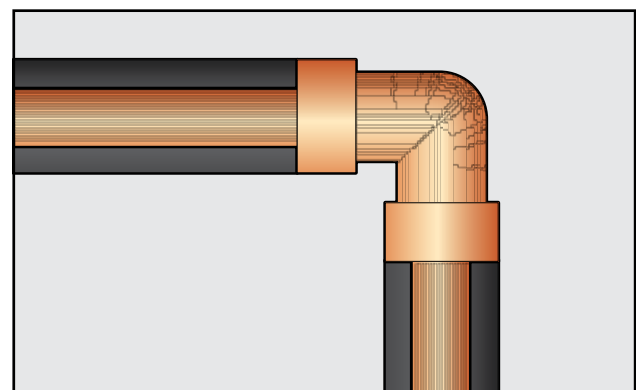

- Select AEROFLEX unslit tube ID that snugly fits over insulated straight run pipe.

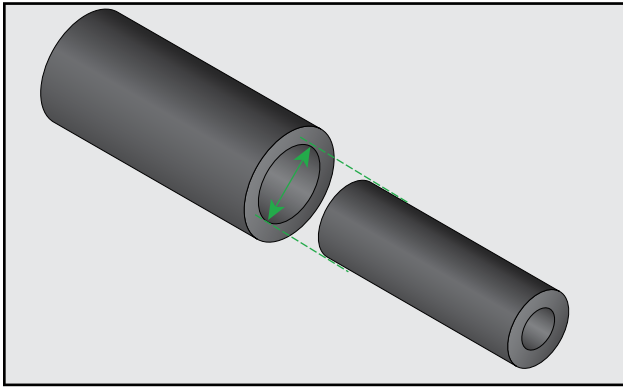

- Cut horizontal and vertical lengths long to install with compression to adjoining tubes.

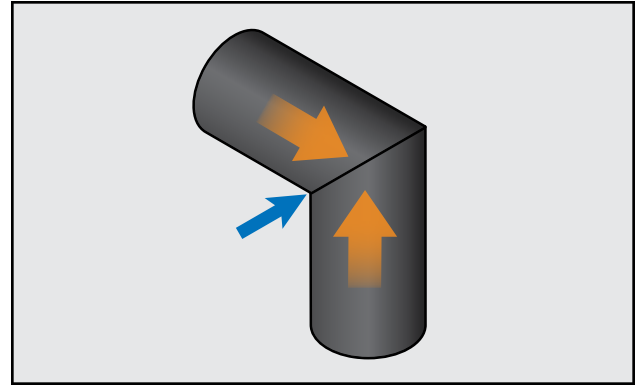

- Once 45° seam is bonded, cut inside radius of insulation fitting (throat).

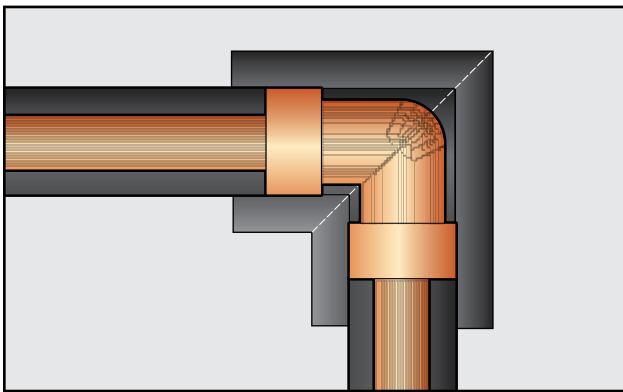

- Cut two (2) segmented pieces to form 90° angle.

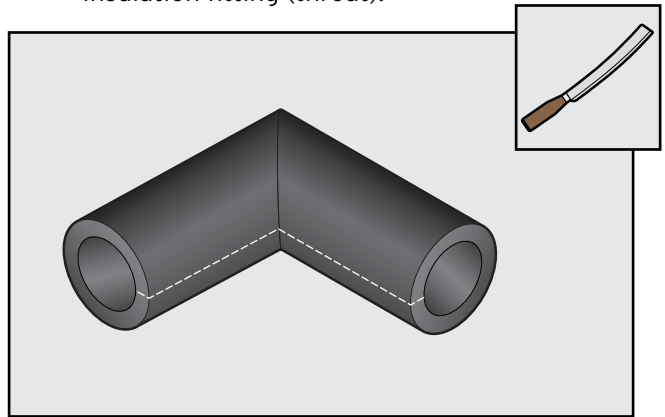

- Install over pipe fitting and glue throat under compression with AEROFLEX adhesive.

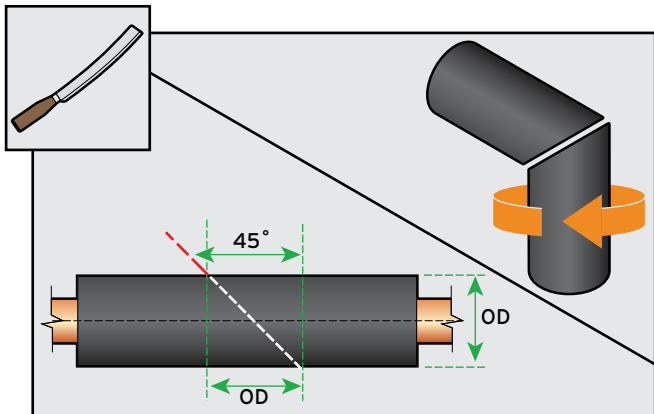

- Glue two (2) sections to form elbow with AEROFLEX adhesive.

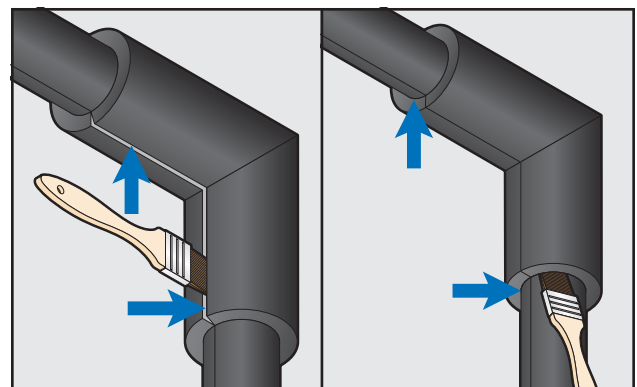

- Glue insulation fitting to outside surface of insulated straight runs under compression with AEROFLEX adhesive.
- Ensure complete vapor seal with no gaps present.
 - Optional: for interior installations, apply Protape over glued longitudinal seams, butt joints and fittings.

- Required: for exterior installations, apply Protape over glued longitudinal seams, butt joints and fittings; turn taped longitudinal seams away from direct sun exposure when possible.
- Optional (recommended): to maximize AEROFLEX life cycle for exterior applications, apply Aerocoat, Aerocoat LVOC or jacketing system for UV protection. For mechanical protection, install jacketing system specifically designed for pipe insulation.

- **Curved Pipe Bends | 90° | Segmented**

- **3-Piece Elbows - Welded** (fitting & piping same diameter)

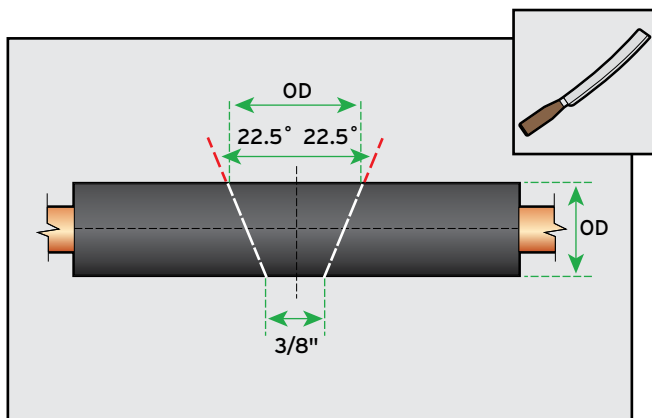
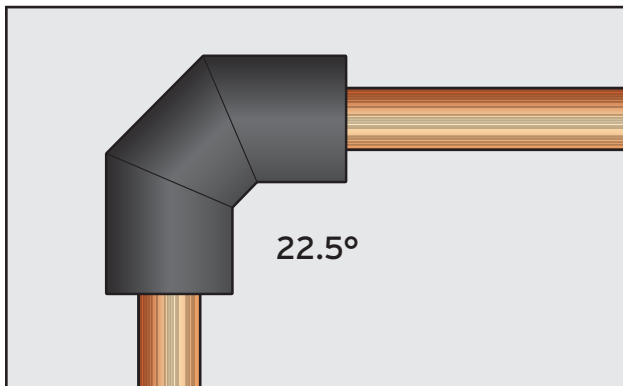

- **3-Piece Elbows - Oversized** (fitting larger than piping)

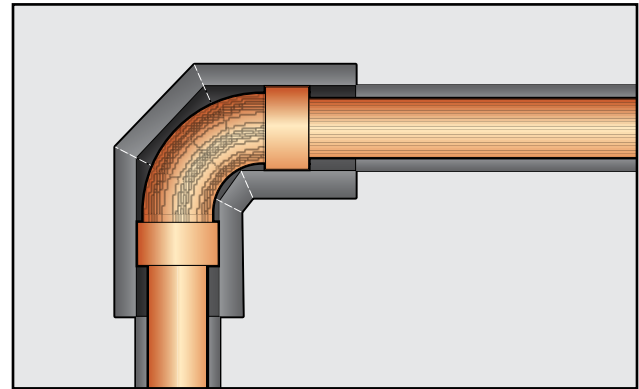

- **4-Piece Elbows - Welded** (fitting & piping same diameter)

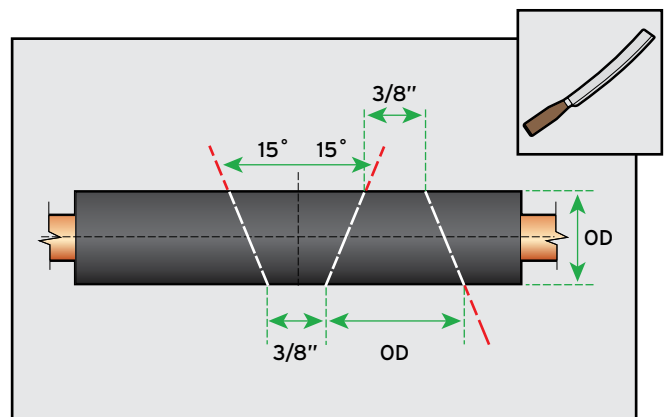
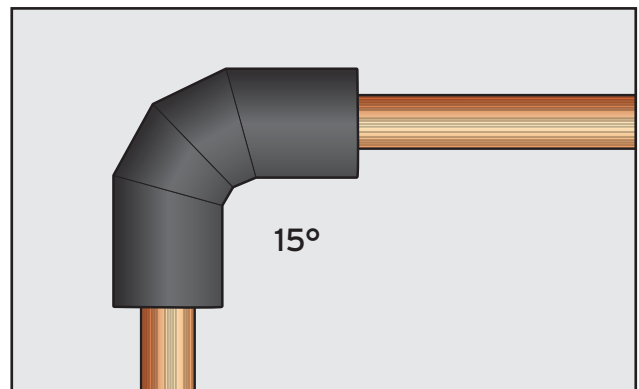

- **4-Piece Elbows - Oversized** (fitting larger than piping)

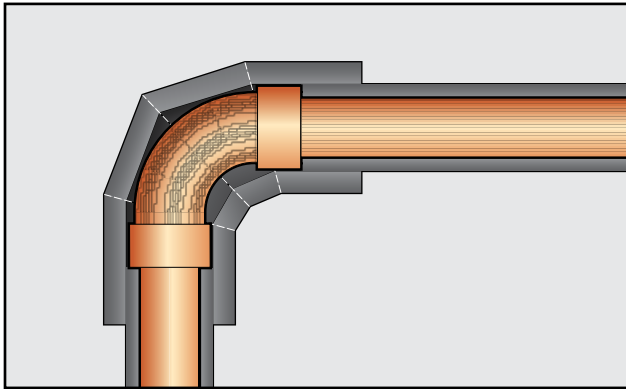

• **5-Piece Elbows - Welded** (fitting & piping same diameter)

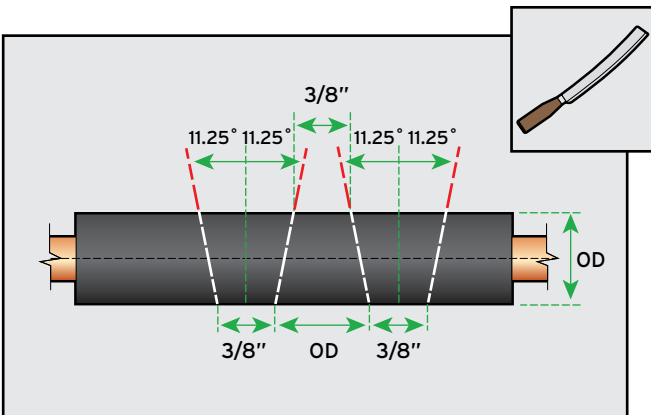
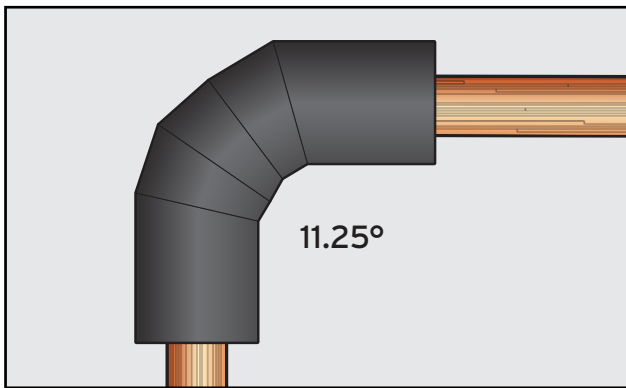

- **Pipe Intersections**

• **Tee's**

- **Hole Punch method**

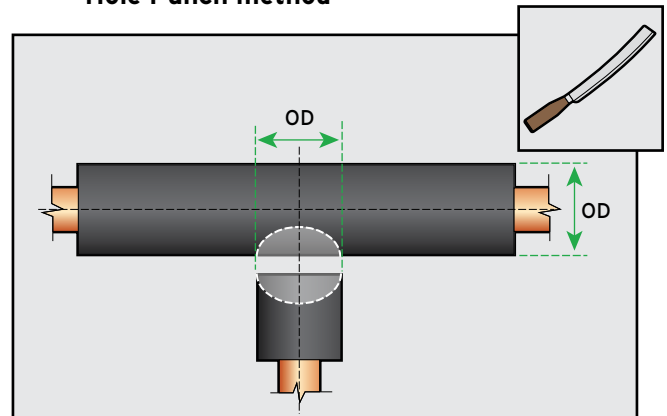

- Punch hole in tube to insulate main (horizontal) pipe with sharpened pipe end of right diameter; use divider to cut hole for larger pipes.
- Slit tube and snap over main pipe at intersection with hole positioned over branch (vertical) pipe.
- At end of tube used for branch (vertical) pipe, cut radiused recess which will contact bottom of main pipe inside horizontal tube.
- Slit tube and snap over branch pipe and join with horizontal tube.
- Glue horizontal and vertical pieces together with AEROFLEX adhesive and to adjoining straight runs.
- Ensure complete vapor seal with no gaps present.
 - Optional: for interior installations, apply Protape over glued longitudinal seams, butt joints and fittings.
 - Required: for exterior installations, apply Protape over glued longitudinal seams, butt joints and fittings; turn taped longitudinal seams away from direct sun exposure when possible; turn taped longitudinal seams away from direct sun exposure when possible.
 - Optional (recommended): to maximize AEROFLEX life cycle for exterior applications, apply Aerocoat, Aerocoat LVOC or jacketing system for UV

protection. For mechanical protection, install jacketing system specifically designed for pipe insulation.

- Miter Box / 90° method

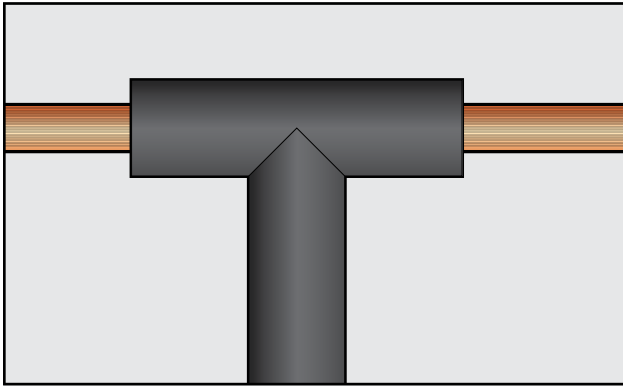

- Using AEROFLEX Template, cut two 45° angles to center at end of tube for branch (vertical) pipe.

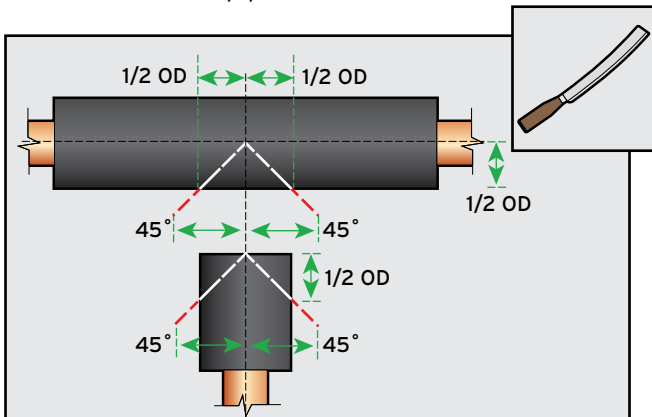

- Cut two 45° angles in bottom center of main (horizontal pipe) at intersection; notch should fit OD of branch pipe.
- Join and glue two fabricated pieces together with AEROFLEX adhesive.
- Slit Tee on sides, snap over pipe intersection and glue seams and butt joints to adjoining straight runs under compression with AEROFLEX adhesive.
- Ensure complete vapor seal with no gaps present.
 - Optional: for interior installations, apply Protape over glued longitudinal seams, butt joints and fittings.

- Required: for exterior installations, apply Protape over glued longitudinal seams, butt joints and fittings; turn taped longitudinal seams away from direct sun exposure when possible.
- Optional (recommended): to maximize AEROFLEX life cycle for exterior applications, apply Aerocoat, Aerocoat LVOC or jacketing system for UV protection. For mechanical protection, install jacketing system specifically designed for pipe insulation.

- 3-Piece Segmented method

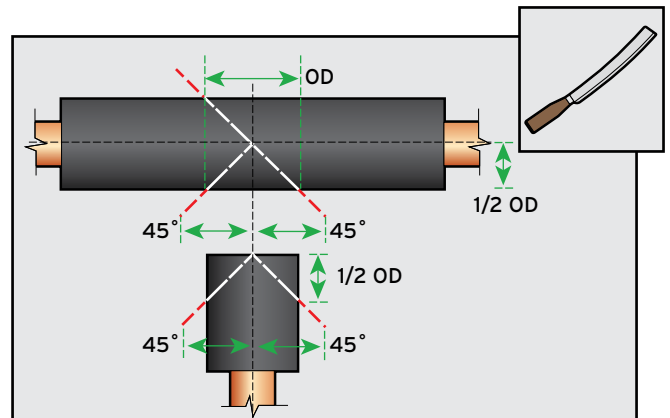
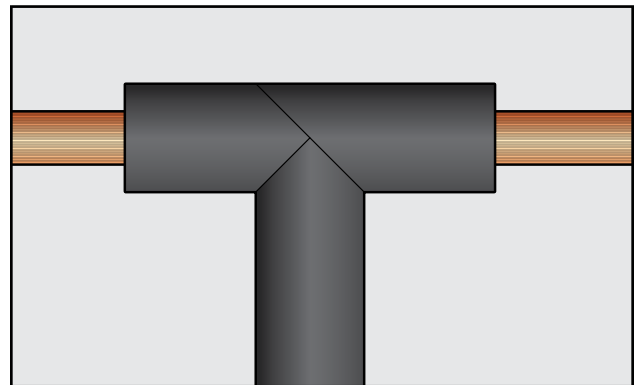

- Using AEROFLEX Template, place tube on baseline.
- Make one 45° cut.
- Make 2nd 45° cut in opposite direction of 1st cut while holding both pieces together.
- Make 3rd 45° cut.
- Lengths of cuts must be equal.
- Join and glue three fabricated pieces together with AEROFLEX adhesive.

- Slit Tee on sides, snap over pipe intersection and glue seams and adjoining straight runs under compression with AEROFLEX adhesive.
- Ensure complete vapor seal with no gaps present.
 - Optional: for interior installations, apply Protape over glued longitudinal seams, butt joints and fittings.
 - Required: for exterior installations, apply Protape over glued longitudinal seams, butt joints and fittings; turn taped longitudinal seams away from direct sun exposure when possible.
 - Optional (recommended): to maximize AEROFLEX life cycle for exterior applications, apply Aerocoat, Aerocoat LVOC or jacketing system for UV protection. For mechanical protection, install jacketing system specifically designed for pipe insulation.

• Cross Joints

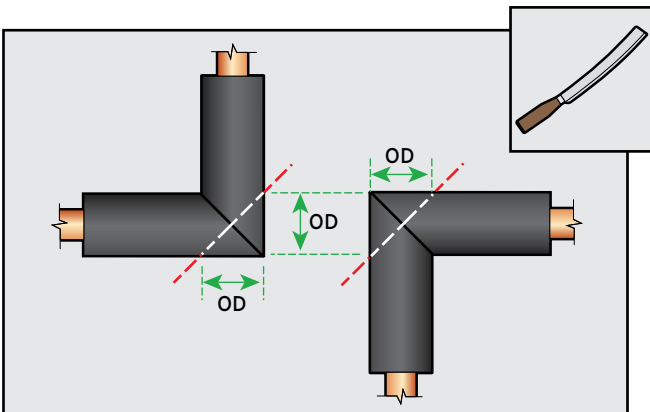
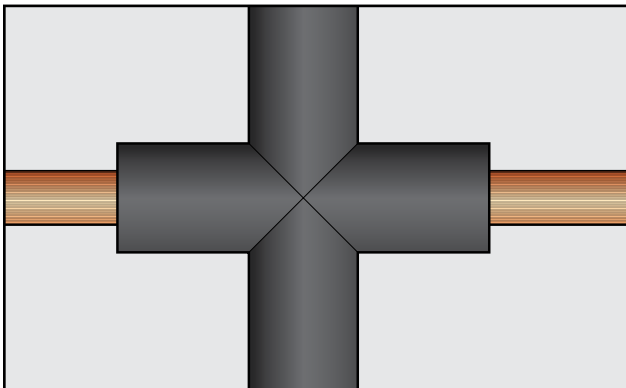

• Angle-T's / Y-Branches

- Cut piece of AEROFLEX unslit tube to correct length for main vertical pipe.

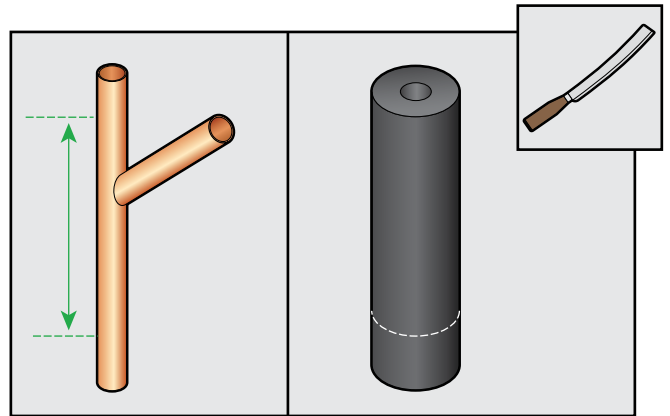

- Punch hole in tube at correct location and angle with hole punch or sharpened copper pipe with the correct OD of branch pipe.

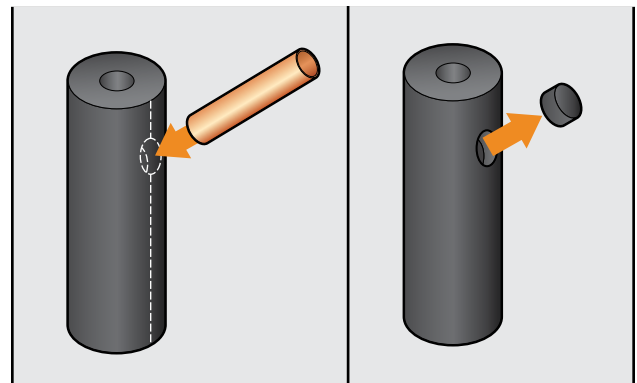

- Cut main vertical tube lengthwise where it intersects with branch pipe and glue seam with AEROFLEX adhesive.

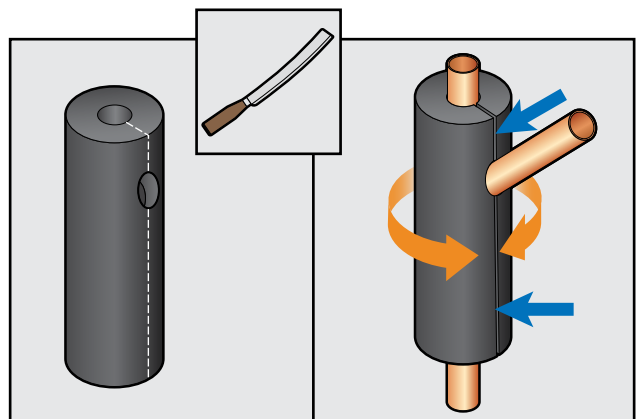

- Using AEROFLEX Template, cut another tube to fit branch pipe with 45° angle cut at one end.

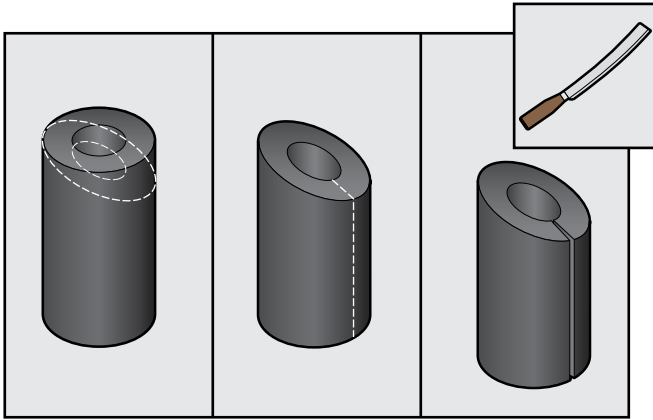

- Cut U-shape at end of 45° cut that meets up with main vertical pipe insulation so there are no gaps.
- Cut mitered piece along one side, fit over pipe and glue seam.
- Glue mitered branch to main pipe under compression with AEROFLEX adhesive.

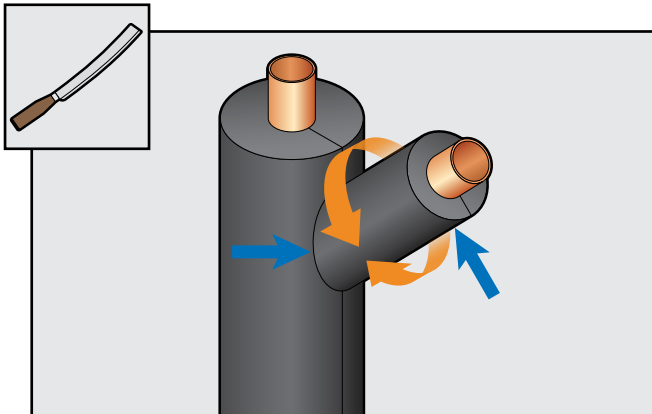

- Ensure complete vapor seal with no gaps present.
 - Optional: for interior installations, apply Protape over glued longitudinal seams, butt joints and fittings.
 - Required: for exterior installations, apply Protape over glued longitudinal seams, butt joints and fittings; turn taped longitudinal seams away from direct sun exposure when possible.
 - Optional (recommended): to maximize AEROFLEX life cycle for exterior applications, apply Aerocoat, Aerocoat LVOC or jacketing

system for UV protection. For mechanical protection, install jacketing system specifically designed for pipe insulation.

• Y-Tubes

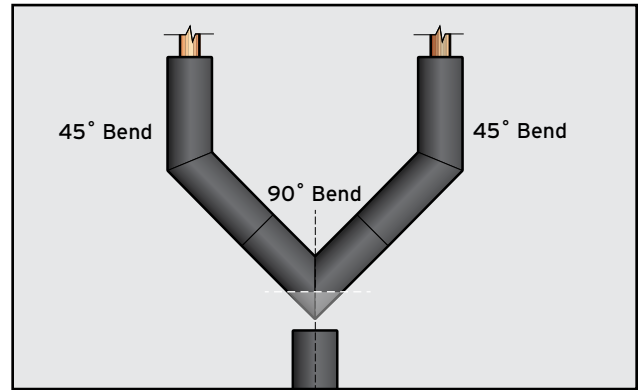

- Collars / Pipe Reducers

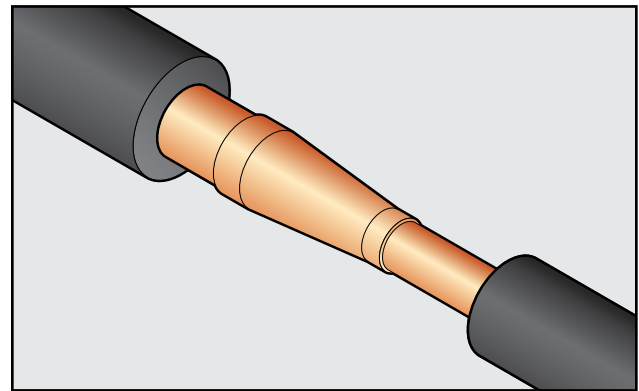

- With piece of AEROFLEX tube the same ID as larger pipe, cut a section larger than opening between straight run tubes installed on either side of pipe transition.

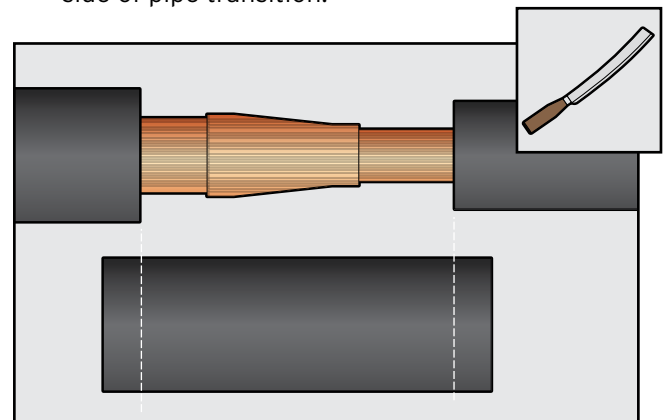

- At one end, cut two equal notches out of opposite sides to fit smaller tube.

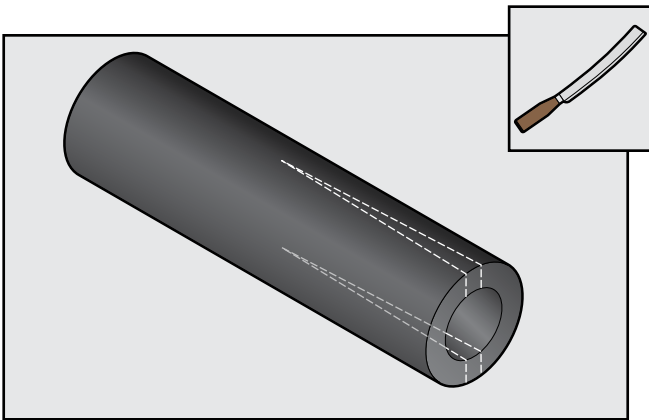

- Glue notched edges together with AEROFLEX adhesive

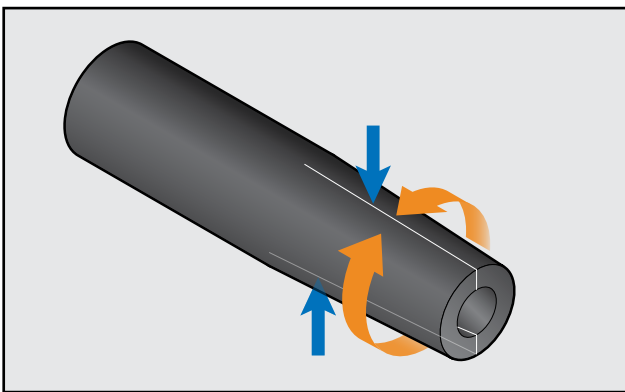

- Cut end of notched size so diameter lines up with OD of smaller tube.
- Cut end of larger ID side so length of reducer is 1/2" longer than opening to allow for 1/4" compression on each side.

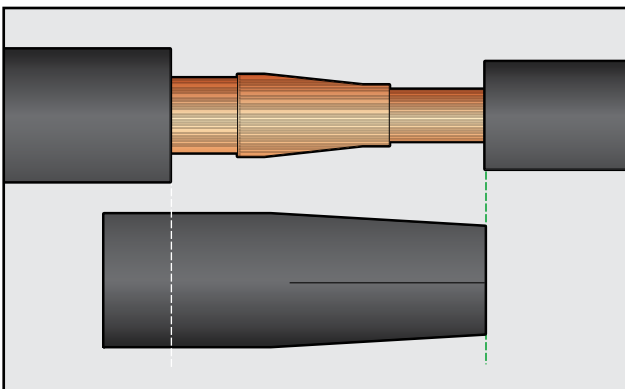

- Cut reducer along entire length and snap on pipe collar.

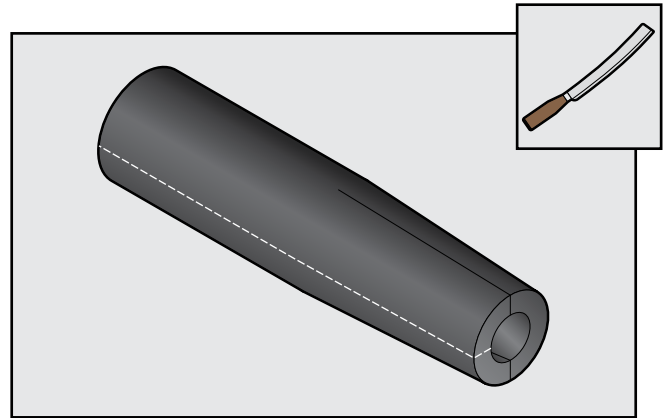

- Glue reducer seam and butt joints under compression with AEROFLEX adhesive.

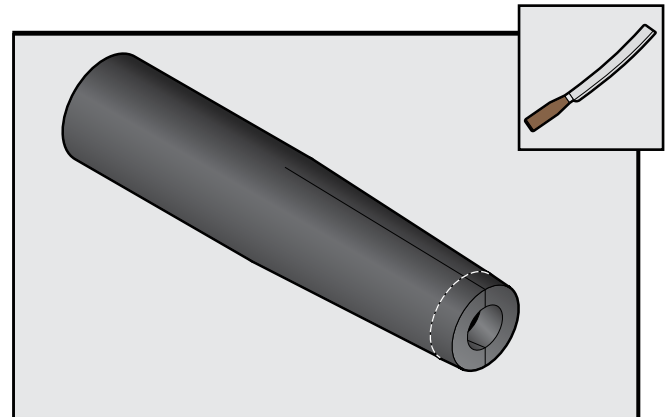

- Ensure complete vapor seal with no gaps present.
 - Optional: for interior installations, apply Protape over glued longitudinal seams, butt joints and fittings.
 - Required: for exterior installations, apply Protape over glued longitudinal seams, butt joints and fittings; turn taped longitudinal seams away from direct sun exposure when possible.
 - Optional (recommended): to maximize AEROFLEX life cycle for exterior applications, apply Aerocoat, Aerocoat LVOC or jacketing system for UV protection. For mechanical protection, install jacketing system specifically designed for pipe insulation.

- **Valves**

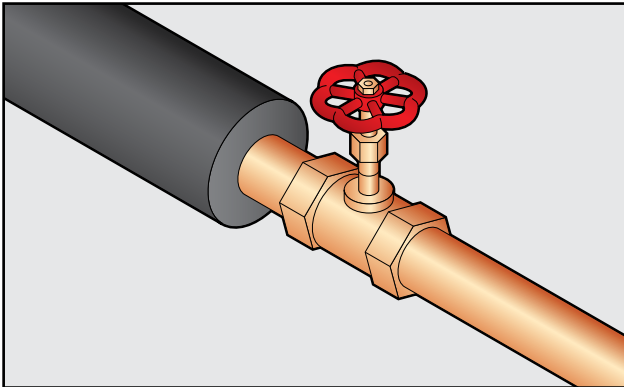

• **Valve stem (small diameter)**

- From edge of straight run tube to center of valve stem, cut and punch hole same diameter as stem.

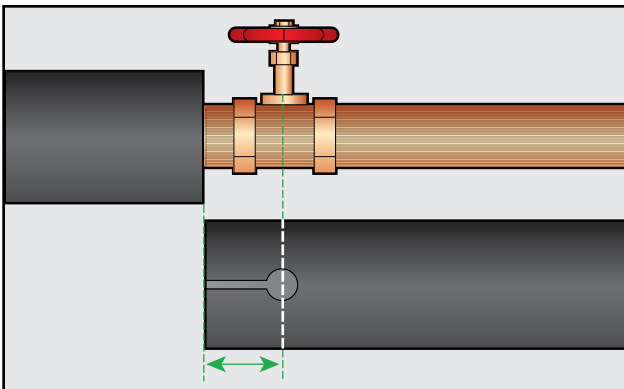

- Install tube on pipe and fit under compression around valve and with adjoining tube.

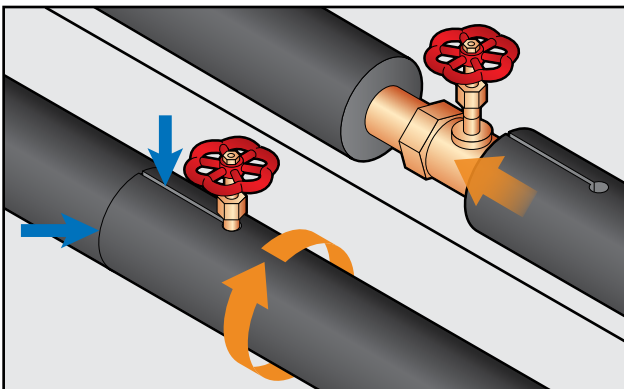

- Glue valve stem, seam between valve stem, end of tube and butt joint under compression with AEROFLEX adhesive.

- Seal all terminations with AEROFLEX adhesive.
- Ensure complete vapor seal with no gaps present.
 - Optional: for interior installations, apply Protape over glued longitudinal seams, butt joints and fittings.
 - Required: for exterior installations, apply Protape over glued longitudinal seams, butt joints and fittings; turn taped longitudinal seams away from direct sun exposure when possible.
 - Optional (recommended): to maximize AEROFLEX life cycle for exterior applications, apply Aerocoat, Aerocoat LVOC or jacketing system for UV protection. For mechanical protection, install jacketing system specifically designed for pipe insulation

• **Valve stem (large diameter)**

- Install straight runs of AEROFLEX pipe insulation up to valve stem.
- Wrap Protape securely around the base of valve.

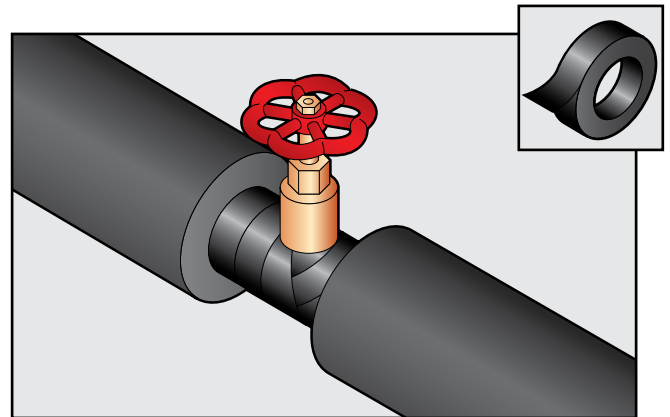

- Cut length of AEROFLEX tube with the same ID as OD of installed tubes; this will be the sleeve.

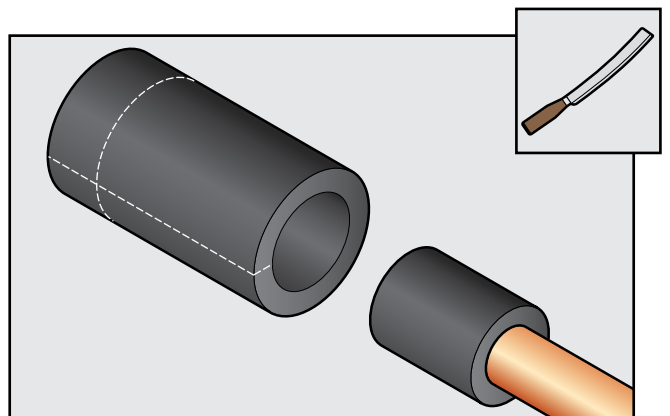

- Slit sleeve along entire length and flatten out.
- Measure and cut seam longitudinally from edge of sleeve to center of valve stem.

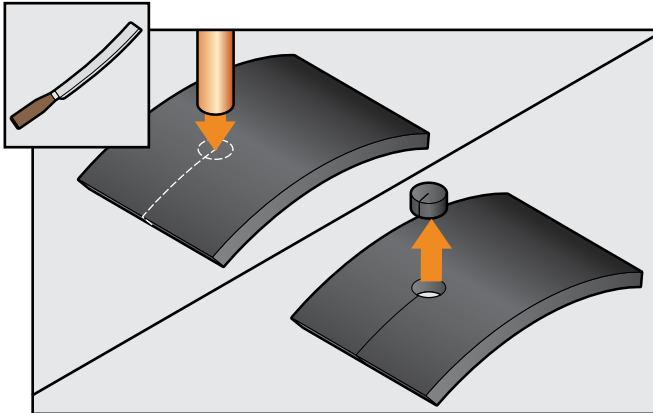

- Punch hole to wrap around valve stem at end of seam.
- Install sleeve over valve and adjoining tubes.

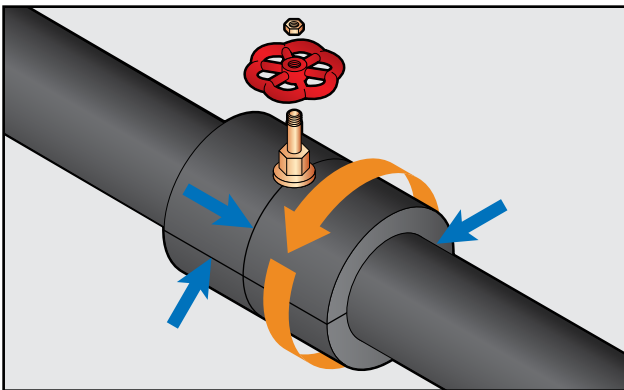

- Glue sleeve to both adjoining tubes and seams within sleeve under compression with AEROFLEX adhesive.
- If space allows between sleeve and valve handle, insulate by fabricating, gluing and installing a donut to insulate the stem.

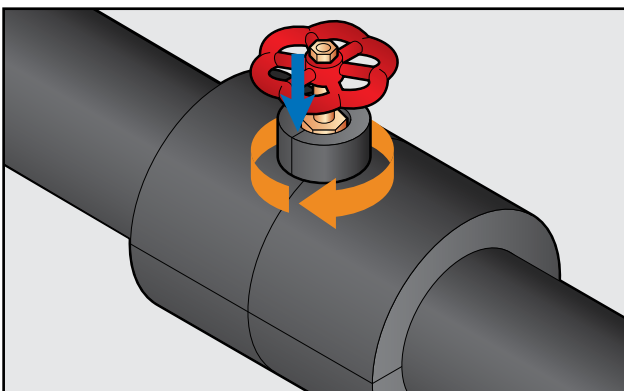

- Seal all terminations with AEROFLEX adhesive.
- Ensure complete vapor seal with no gaps present.
 - Optional: for interior installations, apply Protape over glued longitudinal seams, butt joints and fittings.
 - Required: for exterior installations, apply Protape over glued longitudinal seams, butt joints and fittings; turn taped longitudinal seams away from direct sun exposure when possible.
 - Optional (recommended): to maximize AEROFLEX life cycle for exterior applications, apply Aerocoat, Aerocoat LVOC or jacketing system for UV protection. For mechanical protection, install jacketing system specifically designed for pipe insulation.

- Block at Pipe End (no termination point)

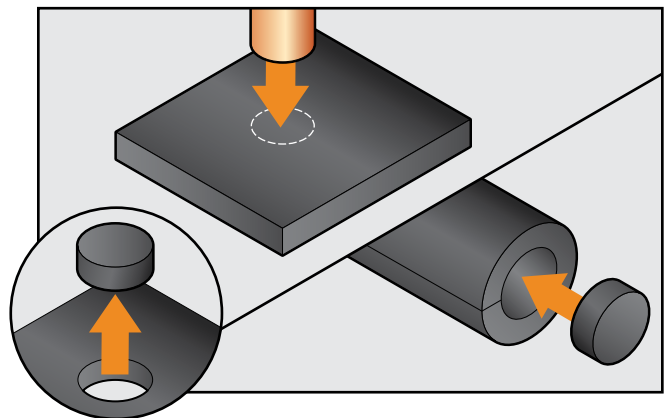

- Using proper sized sharpened pipe end, cut plug out of same thickness of AEROFLEX sheet/roll insulation.
- Glue end of tube ID and fabricated plug with AEROFLEX adhesive.
- Once glue is ready for contact, insert plug in end of tube.
- Ensure complete vapor seal with no gaps present.

LARGE DIAMETER PIPES | ROUND SPIRAL DUCTS

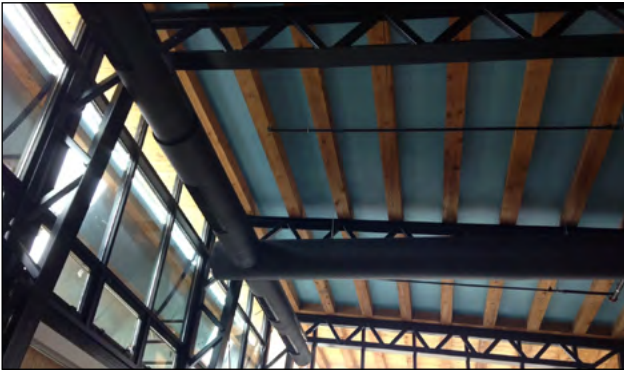

- AEROFLEX Sheet & Roll

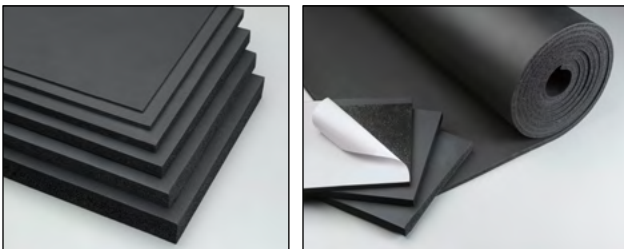

• Sheet:

- Standard Back (no PSA) - available in 3'x4' [.91 m x 1.2 m], thicknesses 1/4" to 3" [.63 cm - 7.6 cm] (ASTM E84 25/50 through 2")
- PSA Back - available in 3'x4' [.91 m x 1.2 m], thicknesses 1/4" to 2-1/2" [.64 cm - 6.4 cm] (ASTM E84 25/50 through 2")

• Roll:

- Standard Back (no PSA) - available in 48" [122 cm] width, thicknesses 1/8" to 2-1/2" [.32 cm - 6.4 cm] (ASTM E84 25/50 through 2")
- PSA Back - available in 48" width [122 cm], thicknesses 1/4" to 2-1/2" [.64 cm - 6.4 cm] (ASTM E84 25/50 through 2")

- Sheet & Roll | Pipe Size Applications

Sheet/Roll Thickness	Outside Pipe Diameter (inches)			
	< 4" [10 cm]	< 5" [13 cm]	< 6" [15 cm]	< 8" [20 cm]
3/8" [.95 cm]	•	•	•	•
1/2" [1.3 cm]	•	•	•	•
3/4" [1.9 cm]	•	•	•	•
1" [2.5 cm]	•	•	•	•
1-1/2" [3.8 cm]		•	•	•
2" [5 cm]				•

- Pipes (straight runs)

- Determine pipe circumference by wrapping strip of AEROFLEX Sheet or Roll, the same thickness to be installed, around pipe; add 1/4" [.64 cm] to measurement.

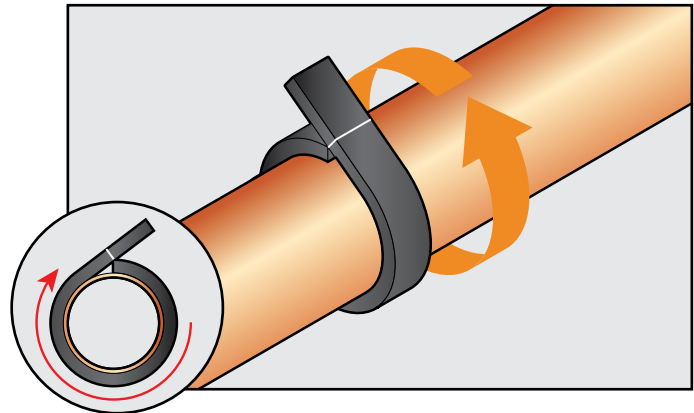

- Do not stretch strip; insulation should fit slightly loose over pipe without stress on seams.
- Mark and cut length of sheet or roll with straight edge.

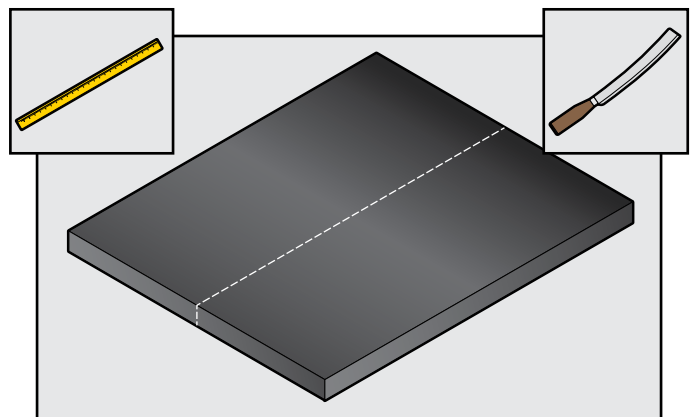

- Apply AEROFLEX adhesive to cut edges of longitudinal seam, allow to tack up until ready for contact.

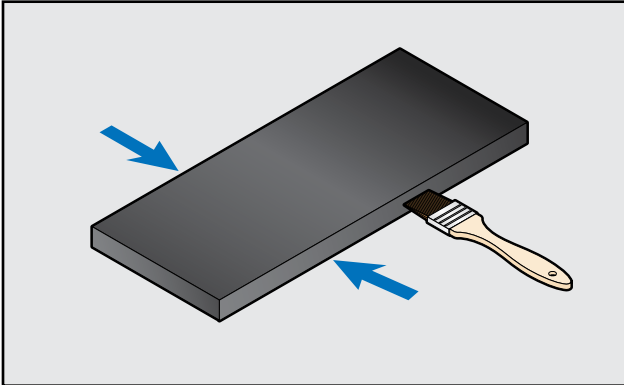

- Place insulation over pipe and adhere glued longitudinal seam by pressing from the outside edges towards the middle to ensure straight edges at butt joints, full adhesion and vapor seal.

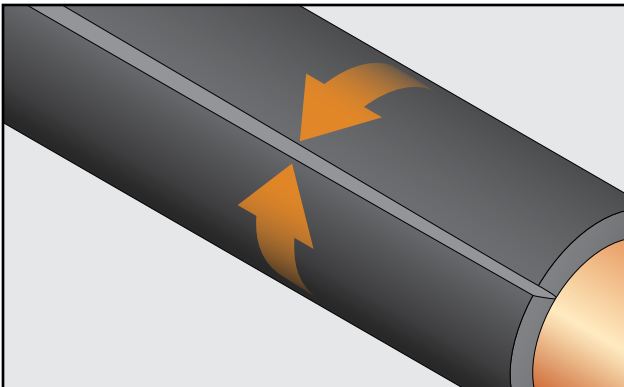

- Glue butt joints under compression with AEROFLEX adhesive.

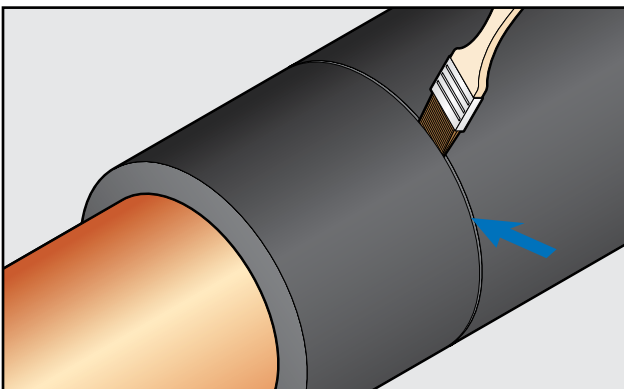

- Ensure complete vapor seal with no gaps present.

- Optional: for interior installations, apply Protape over glued longitudinal seams, butt joints and fittings.
- Required: for exterior installations, apply Protape over glued longitudinal seams, butt joints and fittings; turn taped longitudinal seams away from direct sun exposure when possible.
- Optional (recommended): to maximize AEROFLEX life cycle for exterior applications, apply Aerocoat, Aerocoat LVOC or jacketing system for UV protection. For mechanical protection, install jacketing system specifically designed for pipe insulation.

• **Notes:**

- Full coverage adhesion of sheets/rolls to pipes is not recommended due to variation of expansion/contraction by layer on an operational system.
- Prior to sealing butt joints on *chilled water* or *refrigerant piping*, install vapor stop at all butt joints by applying at least 1/2" [1.3 cm] strip of adhesive to pipe and insulation bonding insulation directly to the pipe.
- To minimize sagging on vertical piping, apply wide (approx. 4" [10 cm]) adhesive strips to pipe and insulation at all butt joints and directly adhere insulation to the pipe.
- For pipe sizes <12" [30 cm] OD, sheets/rolls should be directly adhered to bottom 1/3 of the pipe to prevent sagging.

- **Multi-Layering**

- Ensure that outer skin of first layer is dry and dust-free; clean with denatured alcohol if necessary.
- **Note:** If Aero seal or Aero seal LVOC Black were installed with 1st layer and dry to the touch prior to contact, the 2nd layer may be applied immediately. For REF 1520, allow 24-36 hours cure time for 1st layer.
- Measure outside diameter of 1st insulated layer by applying the same principles when measuring pipe OD for 1st layer.

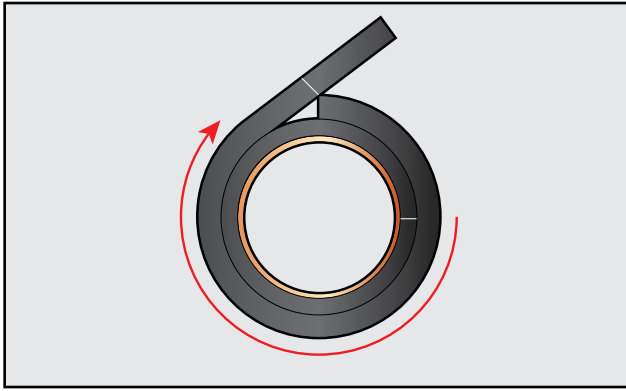

- Mark and cut length of AEROFLEX Sheet & Roll with straight edge; add 1/4" [.64 cm] to measurement.

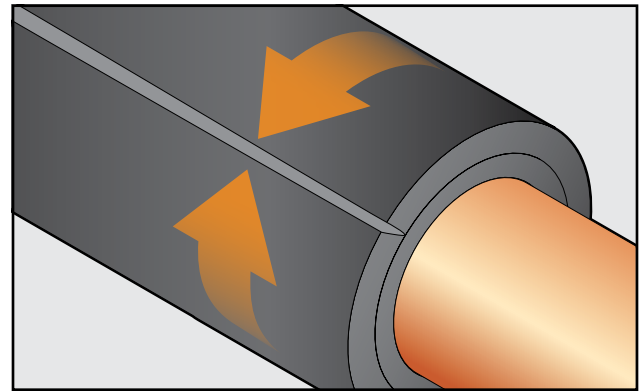

- Ensure that all longitudinal seams and butt joints are staggered; do not overlap the previous layer.

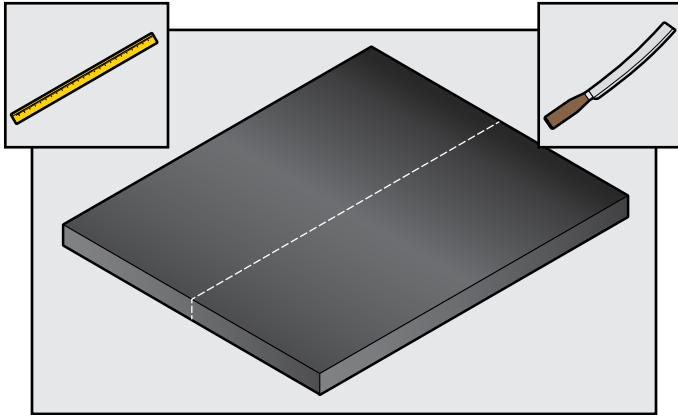

- Apply AEROFLEX adhesive to cut edges of longitudinal seam, allow to tack up until ready for contact.

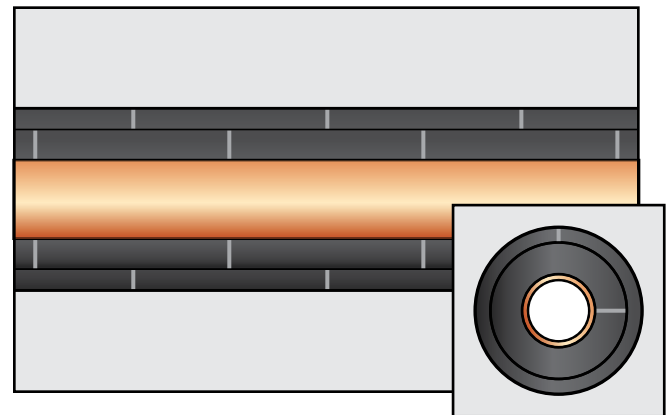

- Glue butt joints under compression with AEROFLEX adhesive.

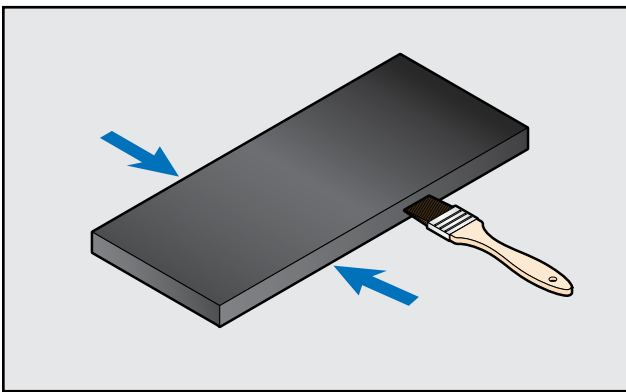

- Place insulation over pipe and adhere glued longitudinal seam by pressing from the outside edges towards the middle to ensure straight edges at butt joints, full adhesion and vapor seal.

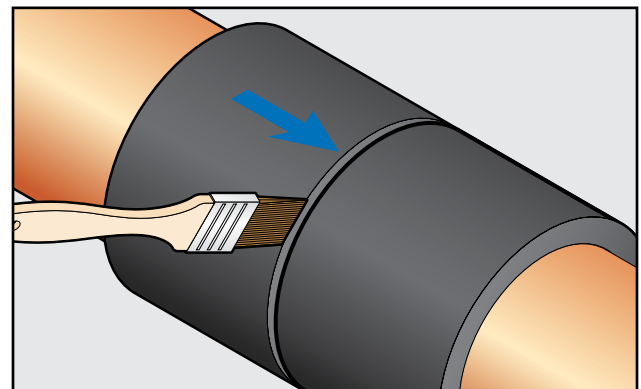

- Ensure complete vapor seal with no gaps present.
 - Optional: for interior installations, apply Protape over glued longitudinal seams, butt joints and fittings.

- Required: for exterior and extreme installations, apply Protape over glued longitudinal seams, butt joints and fittings; turn taped longitudinal seams away from direct sun exposure when possible.
- Optional (recommended): to maximize AEROFLEX life cycle for exterior applications, apply Aerocoat, Aerocoat LVOC or jacketing system for UV protection. For mechanical protection, install jacketing system specifically designed for pipe insulation.

• **Notes:**

- Full coverage adhesion of multiple layers is not recommended due to varied expansion/contraction by layer on an operational system.
- For extreme refrigeration or cryogenic applications, apply Protape over all sealed longitudinal seams and butt joints of 1st layer.

- **Pipe Bends**

• **90° Angles | Elbows**

- Calculate inside (throat) radius (r) by determining intersection of horizontal and vertical lines outside of pipe welds.

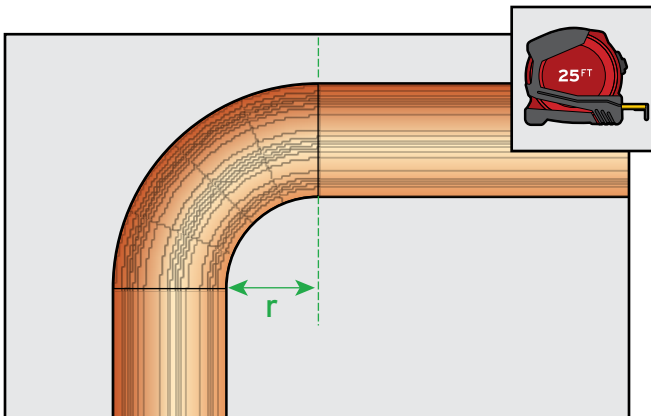

- On AEROFLEX Sheet or Roll, mark line representing insulation thickness along edge of length and width (X & Y axis).

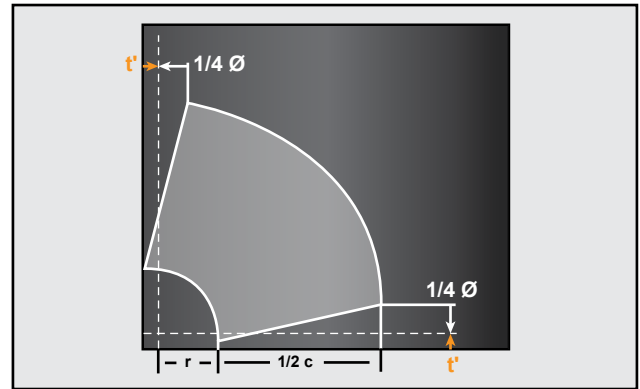

- From the intersection of X & Y axis, mark outline of inside radius with divider.

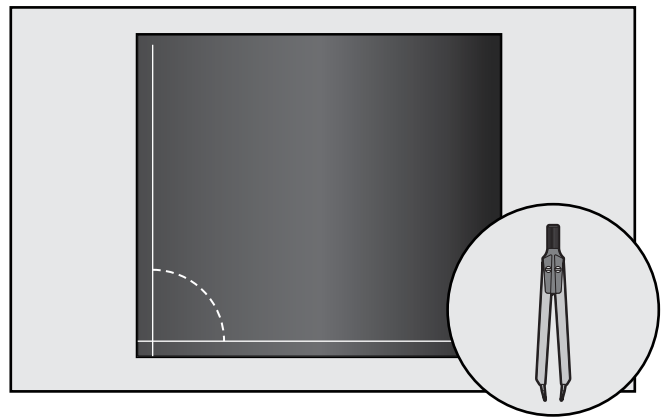

- Measure the circumference of pipe using strip of AEROFLEX Sheet or Roll (same thickness, do not stretch); add 1/4" [.64 cm] to measurement.

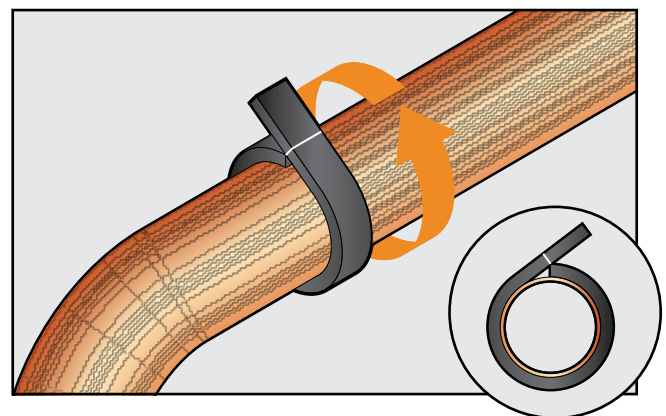

- Divide the circumference (c) by 2 and mark sheet with outer radius from inner radius using divider.

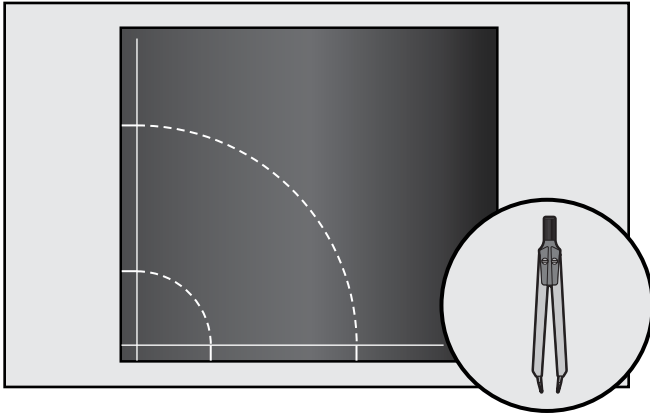

- Cut first half of insulation fitting and use as template to cut out 2nd half.

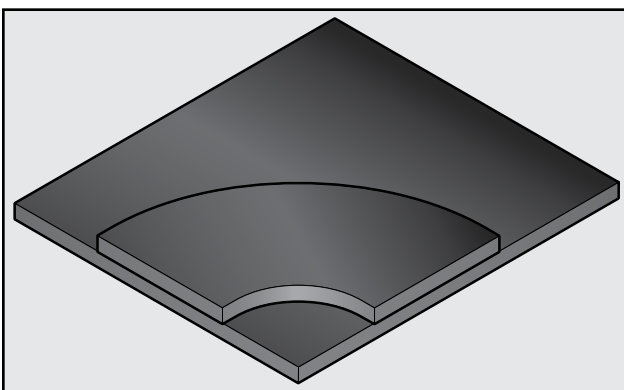
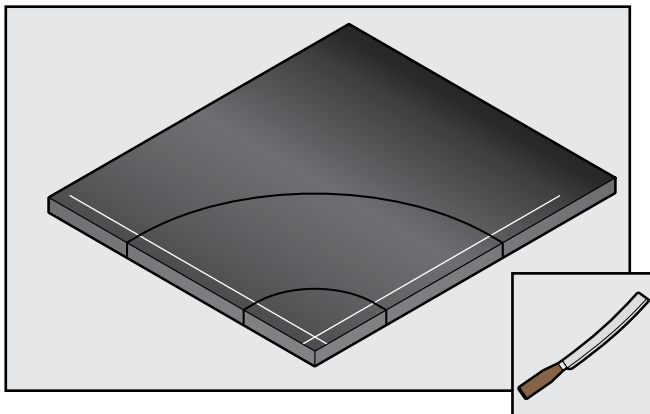

- Position both sides together with smooth skin facing out and apply AEROFLEX adhesive to outer edges.

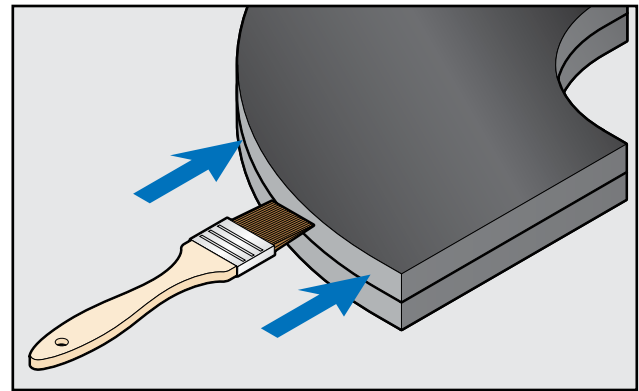

- Once glued edges are ready for contact, adhere outside edges together from the outer edges inwards.

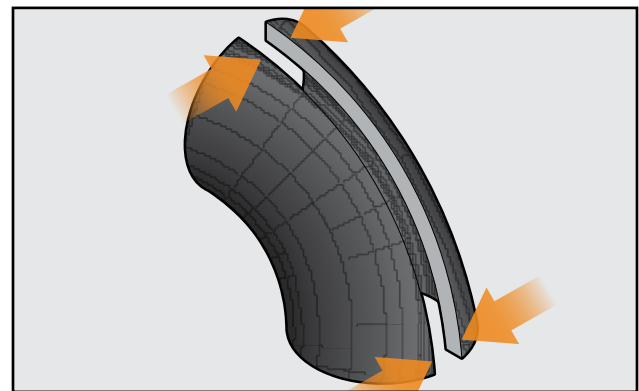

- Turn insulation fitting over, lay flat and apply firm pressure to seam from inside to ensure complete adhesion.

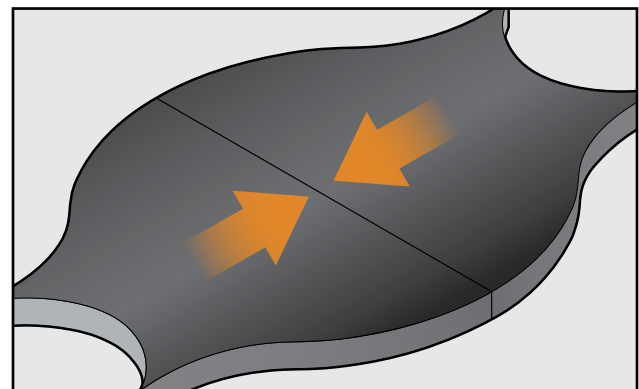

- Apply AEROFLEX adhesive to inside edges and allow to tack.

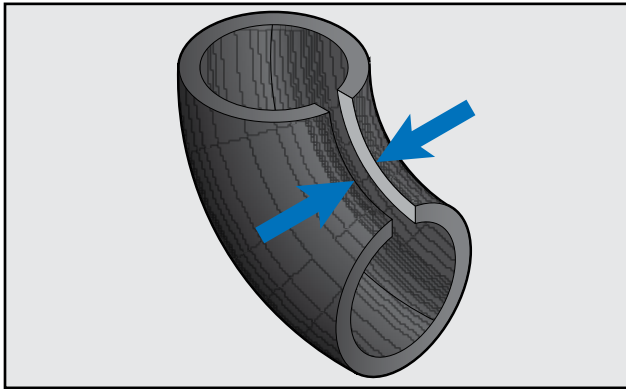

- Once glued inside seam is ready for contact, wrap the insulation fitting around pipe bend and apply firm pressure to ensure complete adhesion.

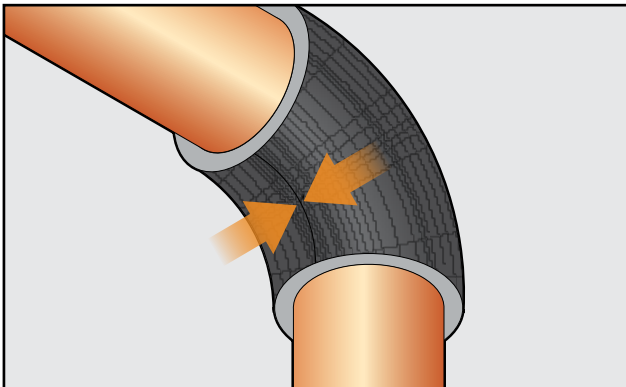

- Glue insulation fitting to butt joints of adjoining tubes under compression with AEROFLEX adhesive.

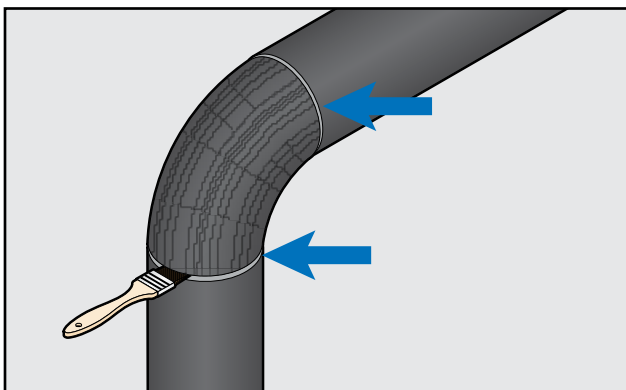

- Ensure complete vapor seal with no gaps present.
- Optional: for interior installations, apply Protape over glued butt joints and fitting seams.

- Required: for exterior and extreme installations, apply Protape over glued butt joints and fitting seams; turn taped seams away from direct sun exposure whenever possible.
- Optional (recommended): to maximize AEROFLEX life cycle for exterior applications, apply Aerocoat, Aerocoat LVOC or jacketing system for UV protection. For mechanical protection, install jacketing system specifically designed for pipe insulation.

• Miter Angles | Bevel Joints

- Measure the circumference of pipe using strip of AEROFLEX Sheet or Roll (same thickness, do not stretch); add 1/4" [.64 cm] to measurement.

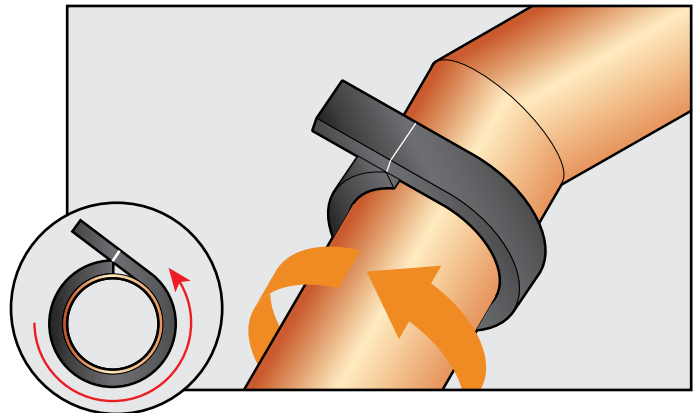

- Measure the inner height (X) and out height (Y) of miter joint.

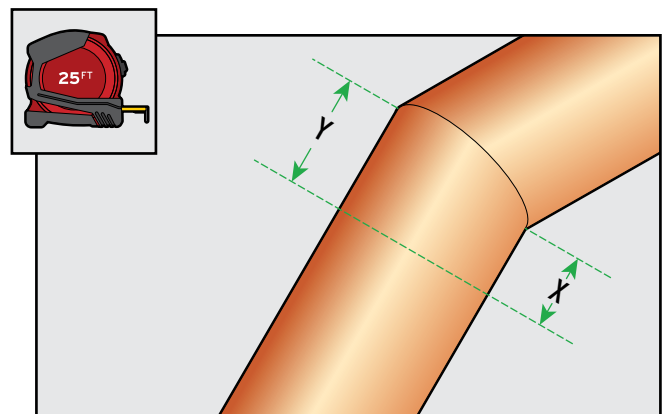

- Using strip used to measure circumference of pipe (Z), mark circumference and center line

on bottom edge of AEROFLEX sheet.

- Mark inner (X) and outer (Y) measurements to perpendicular edge of sheet.

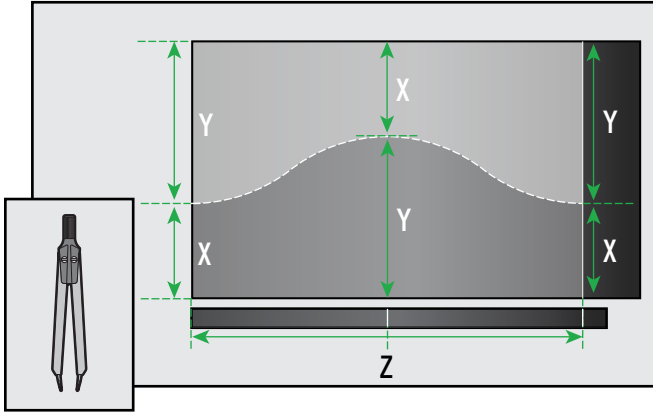

- Using divider, mark arcs measuring 1/2 of the circumference.

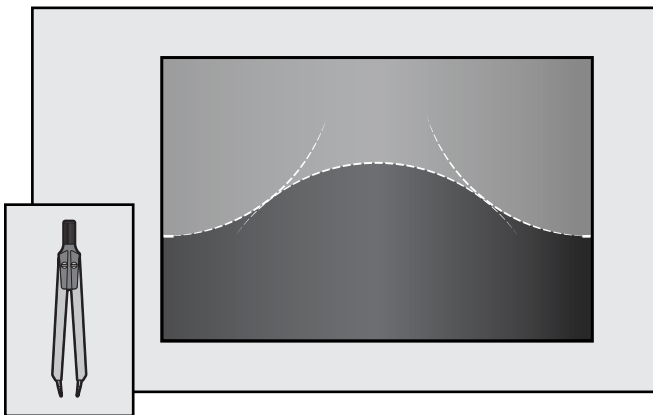

- Draw continuous line to join arcs and cut along line.

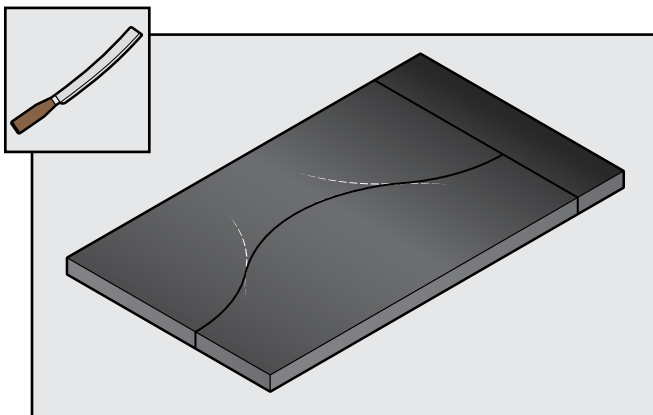

- Flip both cut pieces 180° to create upper and lower sections of miter joint.

- Apply AEROFLEX adhesive to longitudinal and miter seam; allow to tack.

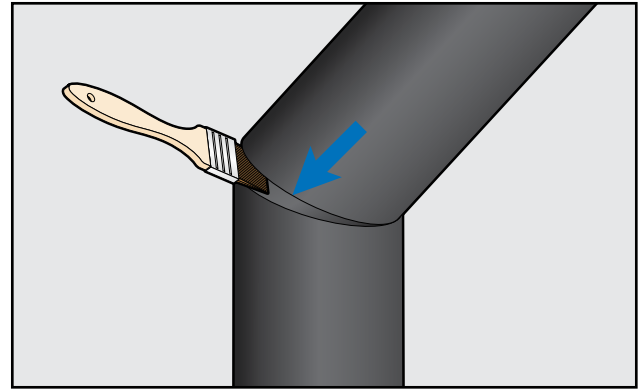

- When ready for contact, join longitudinal seam first followed by miter seam with firm pressure under compression.

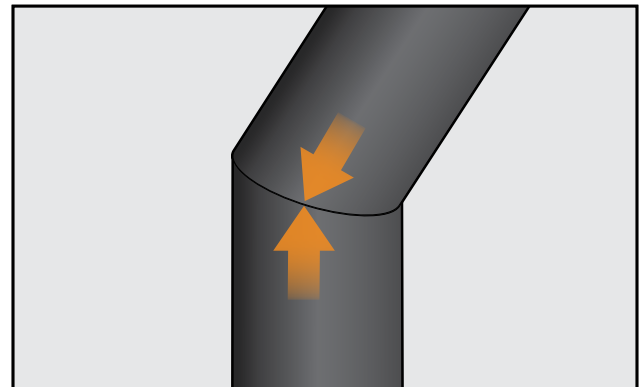

- Ensure complete vapor seal with no gaps present.
 - Optional: for interior installations, apply Protape over glued butt joints and fitting seams.
 - Required: for exterior and extreme installations, apply Protape over glued butt joints and fitting seams.
 - Optional (recommended): to maximize AEROFLEX life cycle for exterior applications, apply Aerocoat, Aerocoat LVOC or jacketing system for UV protection. For mechanical protection, install jacketing system specifically designed for pipe insulation.

- Pipe Intersections | One-Piece T

- Measure length of main pipe (X) and branch pipe (Y).

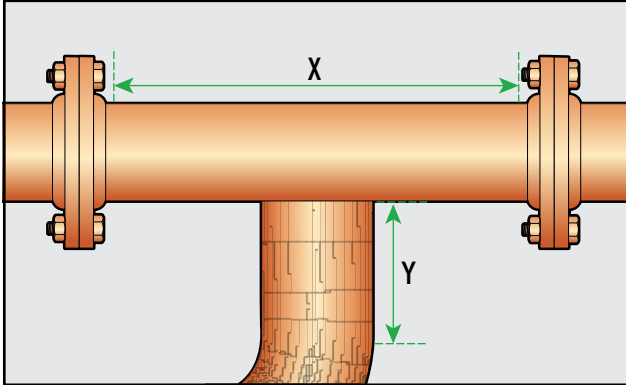

- With strip of AEROFLEX Sheet the same thickness as insulation to be installed, measure the circumference of main and branch pipes (do not stretch); add 1/4" [.64 cm] to measurement.

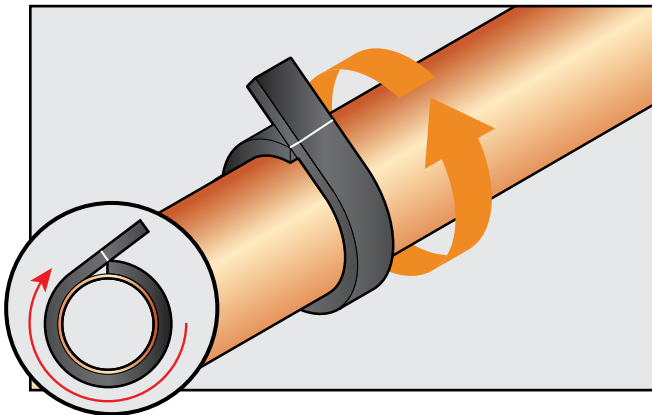

- Mark horizontal and vertical measurements on AEROFLEX sheet.

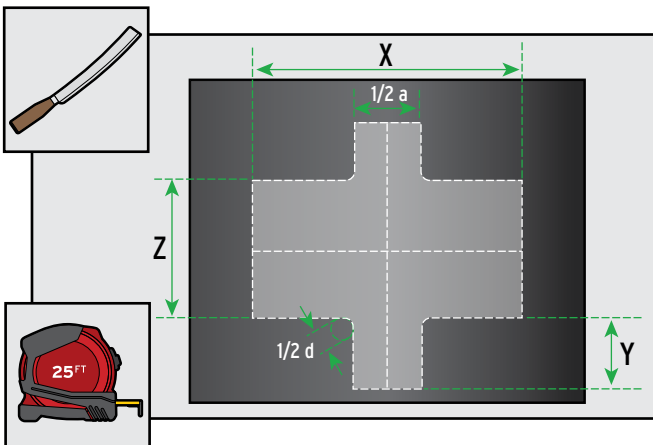

- For branch pipe, mark the center and to both sides of vertical line.
- Mark 1/2 diameter of branch pipe with straight lines and cut out sections.
- Apply AEROFLEX adhesive to edges of fabricated T insulation fitting and allow to tack.
- Once glued edges are ready for contact, wrap T insulation fitting around pipe intersection and apply firm pressure under compression to glued seams to ensure complete adhesion and vapor seal.

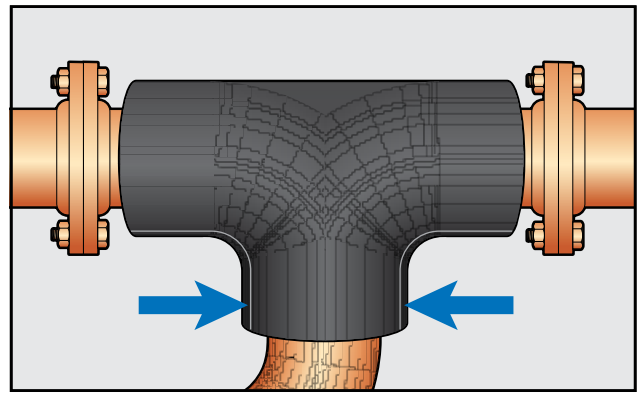

- Once straight run pipe insulation and flange insulation fitting are installed, glue T insulation fitting to flange insulation fitting under compression with AEROFLEX adhesive.
- Ensure complete vapor seal with no gaps present.

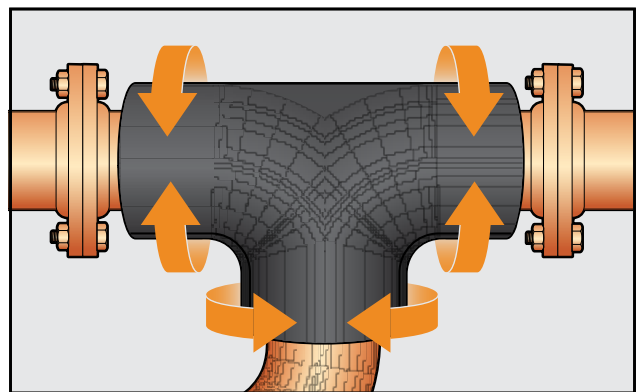

- Optional: for interior installations, apply Protape over glued butt joints and T insulation fitting seams.
- Required: for exterior and extreme installations, apply Protape over glued butt joints and T insulation fitting seams.

- Optional (recommended): to maximize AEROFLEX life cycle for exterior applications, apply Aerocoat, Aerocoat LVOC or jacketing system for UV protection. For mechanical protection, install jacketing system specifically designed for pipe insulation.

- Collars | Pipe Reducers

• Concentric

- Measure length and diameters of large and small pipes.

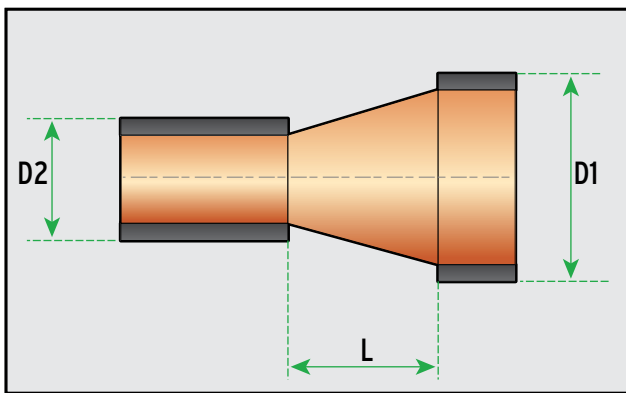

- L = length of reducer including weld on both sides
- $D1$ = diameter of larger pipe + 2x insulation thickness
- $D2$ = diameter of smaller pipe + 2x insulation thickness
- Transfer L , $D1$ and $D2$ measurements to AEROFLEX Sheet; draw lines from ends of both measurements to point.

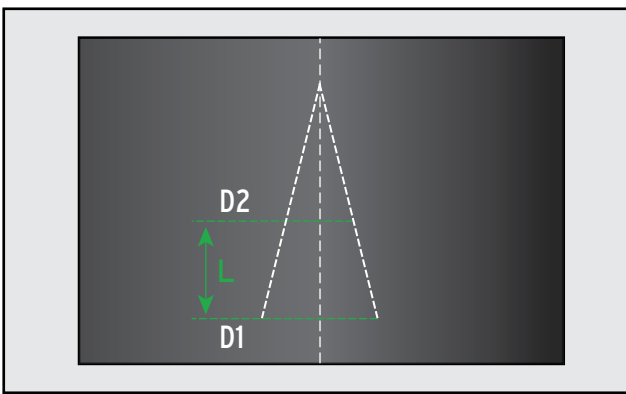

- With divider, draw two arcs.

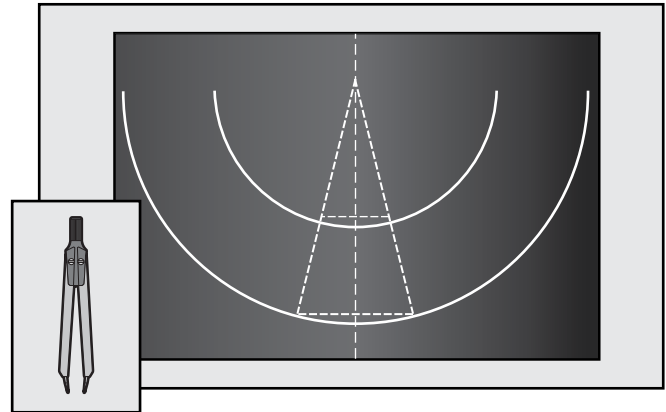

- Measure circumference of larger pipe with strip of AEROFLEX Sheet of same thickness as insulation on larger pipe (do not stretch); add 1/4" [.64 cm] to measurement.
- Mark center of circumference strip and place on larger arc; draw lines from both ends of strip to center.

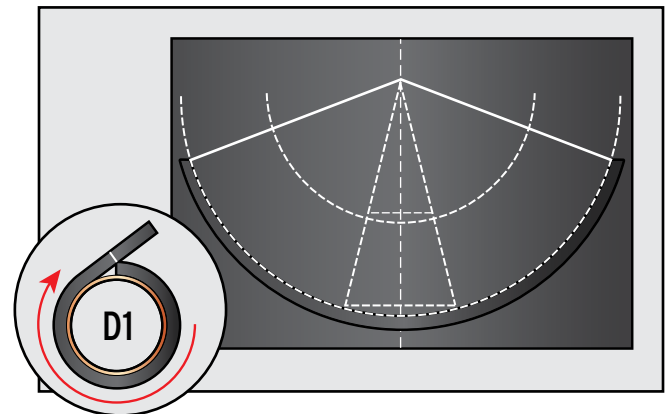

- Carefully cut out reducer from sheet.

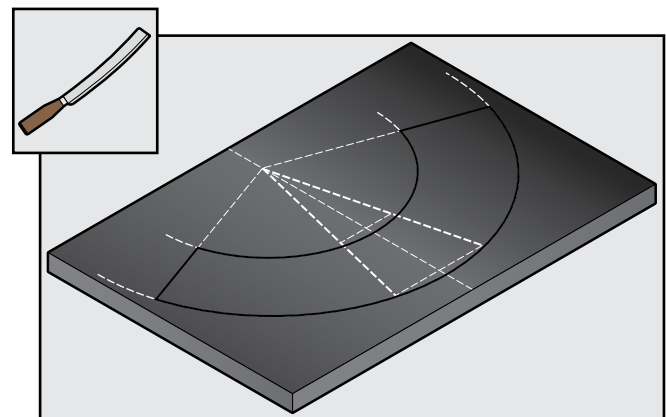

- Apply AEROFLEX adhesive to both edges of reducer seam and allow to tack.
- Once ready for contact, wrap insulation fitting over reducer and firmly adhere from the outer edges to center to ensure flush edges at seam.

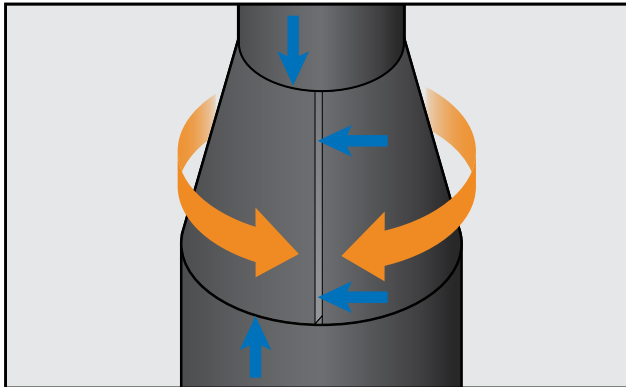

- Glue butt joints of reducer fitting to insulation on large and small pipes under compression with AEROFLEX adhesive.
- Ensure complete vapor seal with no gaps present.
 - Optional: for interior installations, apply Protape over glued butt joints and reducer insulation fitting seams.
 - Required: for exterior and extreme installations, apply Protape over glued butt joints and reducer insulation fitting seams; turn taped longitudinal seams away from direct sun exposure when possible.
 - Optional (recommended): to maximize AEROFLEX life cycle for exterior applications, apply Aerocoat, Aerocoat LVOC or jacketing system for UV protection. For mechanical protection, install jacketing system specifically designed for pipe insulation.

• Eccentric

- Measure length and diameters of large and small pipes.

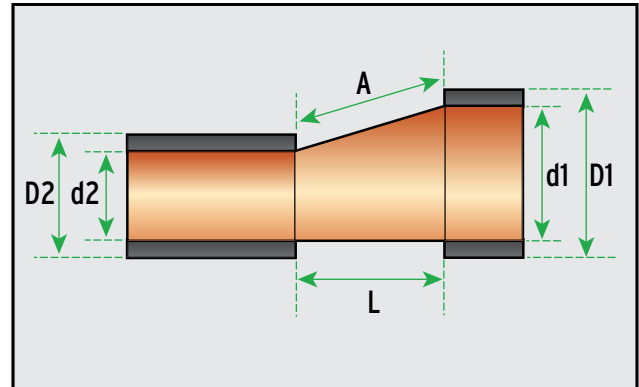

- L = length of reducer including weld on both sides
- A = angled length of reducer
- D1 = diameter of larger pipe + 2x insulation thickness
- D2 = diameter of smaller pipe + 2x insulation thickness
- Transfer L, A, D1 and D2 measurements to AEROFLEX Sheet.

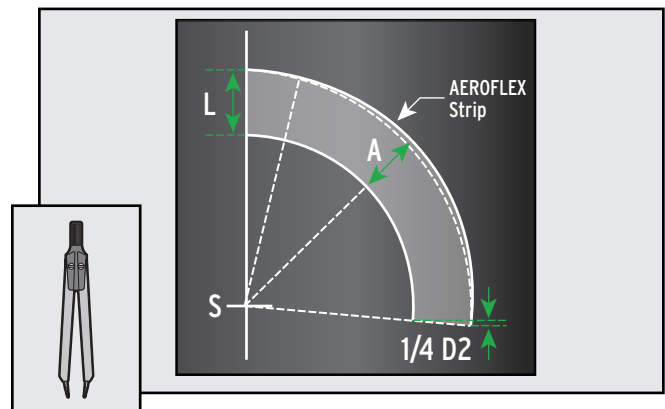
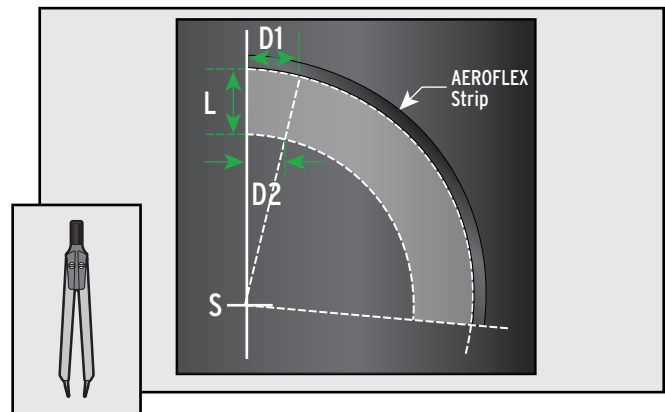

- Carefully cut out reducer from sheet.

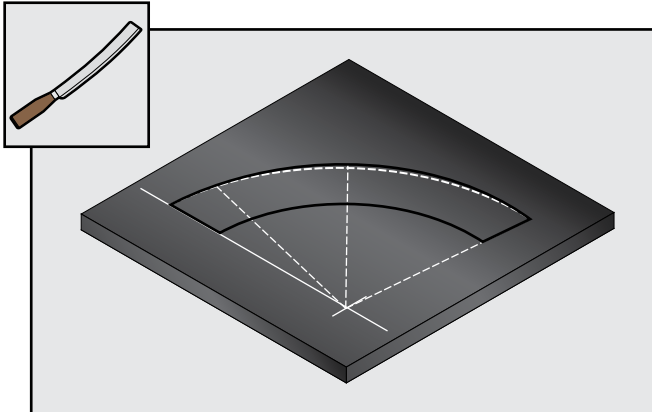

- Apply AEROFLEX adhesive to both edges of reducer seam and allow to tack.
- Once ready for contact, wrap insulation fitting over reducer and firmly adhere from the outer edges to center to ensure flush edges at seam.

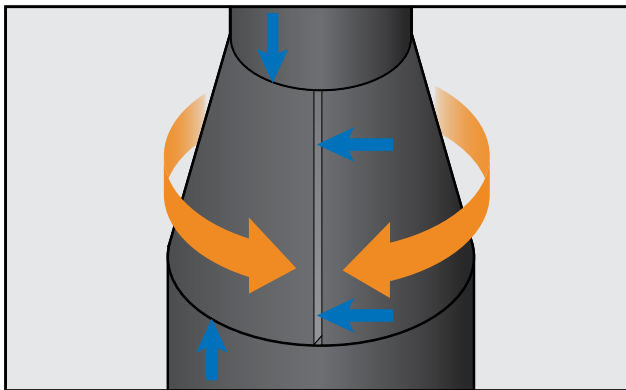

- Glue butt joints of reducer fitting to insulation on large and small pipes under compression with AEROFLEX adhesive.
- Ensure complete vapor seal with no gaps present.
 - Optional: for interior installations, apply Protape over glued butt joints and reducer insulation fitting seams.
 - Required: for exterior and extreme installations, apply Protape over glued butt joints and reducer insulation fitting seams; turn taped longitudinal seams away from direct sun exposure when possible.
 - Optional (recommended): to maximize AEROFLEX life cycle for exterior applications, apply Aerocoat, Aerocoat LVOC or jacketing system for UV protection. For mechanical

protection, install jacketing system specifically designed for pipe insulation.

- Flanges

- Insulate adjoining pipes up to flange.

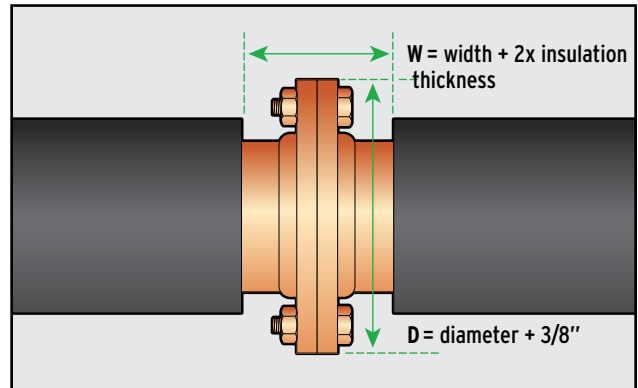

- **Note:** for chilled water or refrigeration systems, insert and glue strips of AEROFLEX insulation between flange bolts.

- Using caliper, measure circumference of insulated pipe.

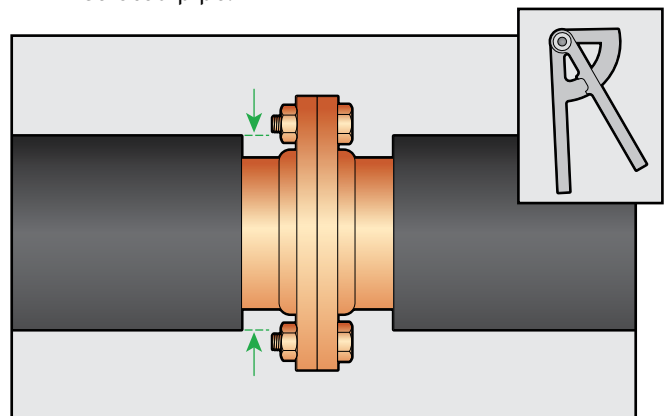

- Using caliper, measure circumference of flange.

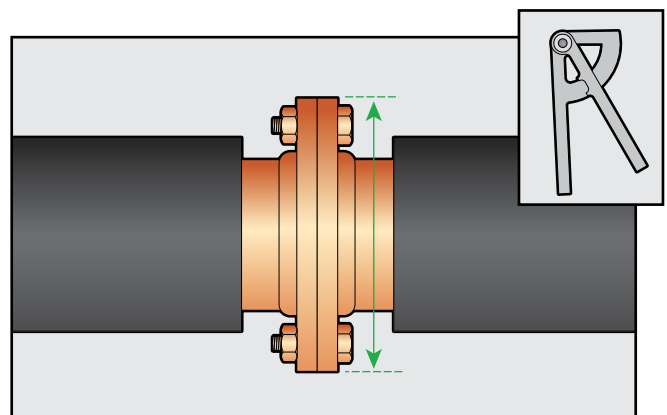

- Using divider, draw inner and outer circumferences on two separate pieces of AEROFLEX Sheet.

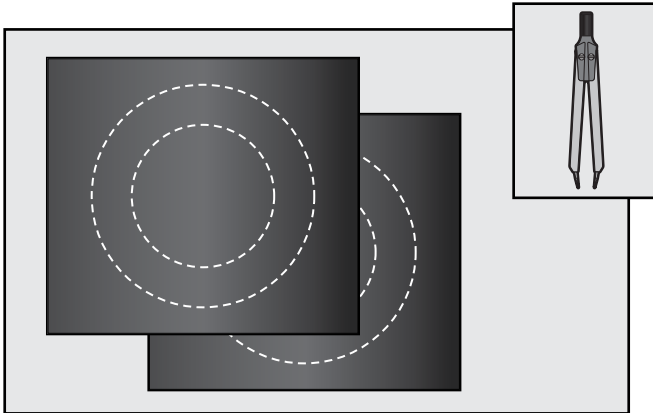

- Measure circumference of rings with strip of AEROFLEX Sheet that is the same thickness (do not stretch); add 1/4" [.64 cm] to measurement.

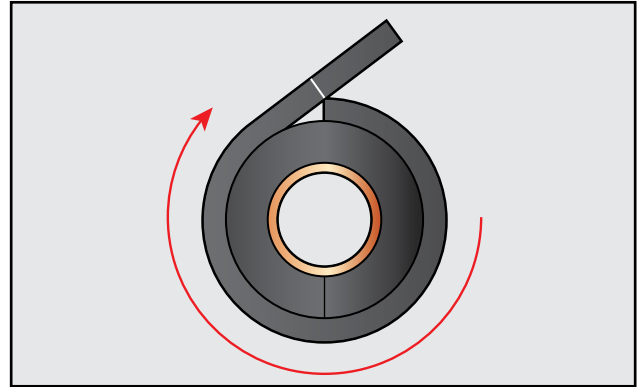

- Carefully cut out both rings and slit one side to wrap around flange.

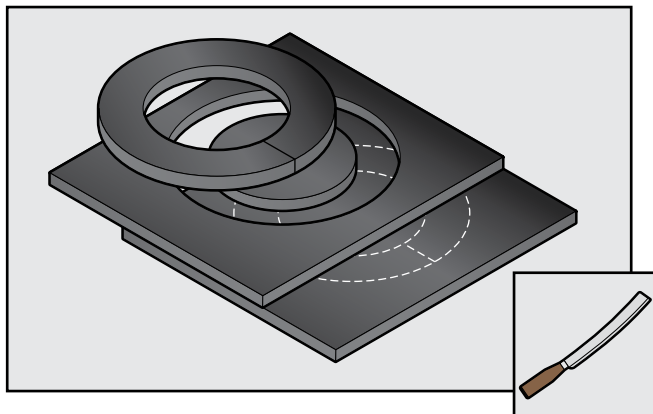

- Measure width of insulated flange.

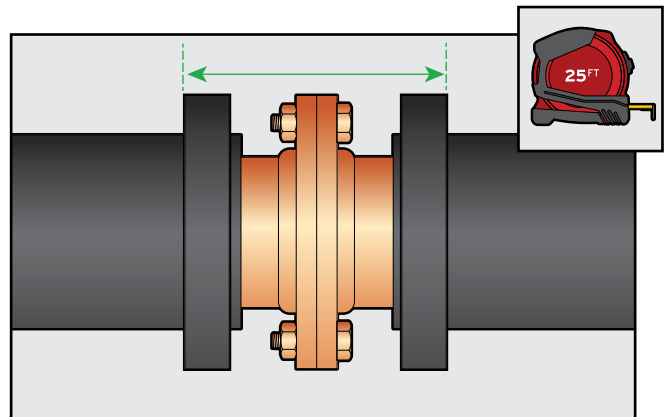

- Wrap rings around pipes on both sides of flange and fully adhere to insulation inserts and bolts with AEROFLEX adhesive; do not glue rings to installed pipe insulation yet.

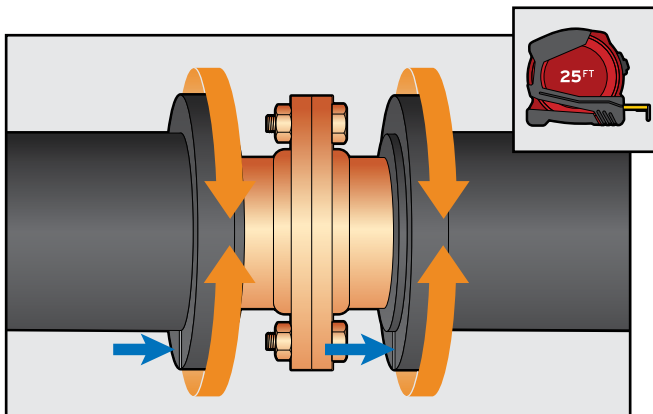

- Draw with straight edge and cut flange jacket from AEROFLEX Sheet.

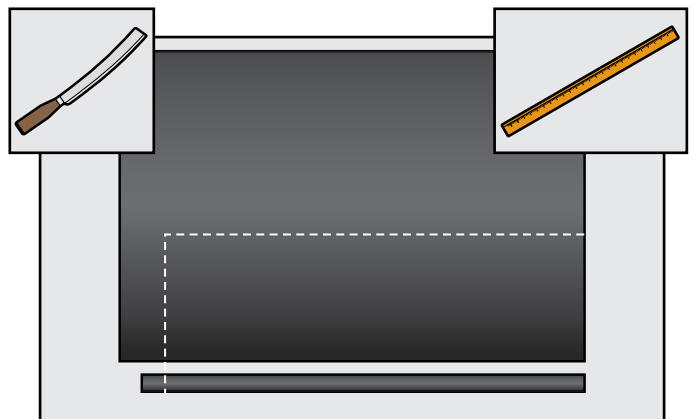

- Wrap jacket around rings to confirm proper fit (not stretched).

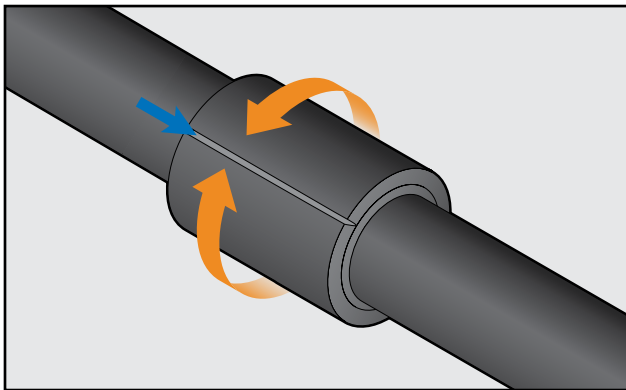

- Apply AEROFLEX adhesive to inside of long edges and horizontal seam of jacket and outside edges of rings and allow to tack.
- When ready for contact, carefully adhere jacket to rings with flush edges under compression; glue inside radius of rings to pipe insulation with AEROFLEX adhesive under compression.

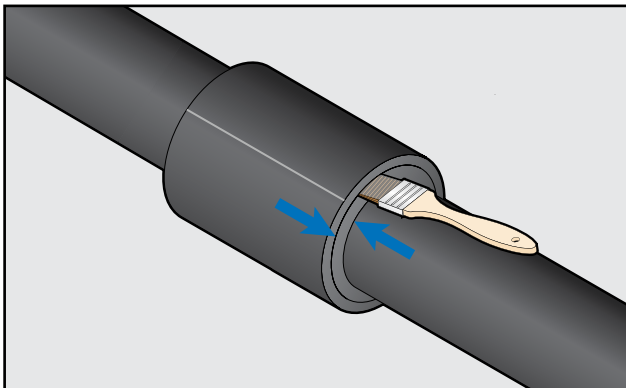

- Ensure complete vapor seal with no gaps present.
 - Optional: for interior installations, apply Protape over glued butt joints and flange insulation fitting seams.
 - Required: for exterior and extreme installations, apply Protape over glued butt joints and flange insulation fitting seams; turn taped longitudinal seams away from direct sun exposure when possible.
 - Optional (recommended): to maximize AEROFLEX life cycle for exterior applications, apply Aerocoat, Aerocoat LVOC or jacketing system for UV protection. For mechanical protection, install jacketing system specifically designed for pipe insulation.

- Valves

• Body

- Insulate adjoining pipes up to flange; valve body should always be insulated after piping.

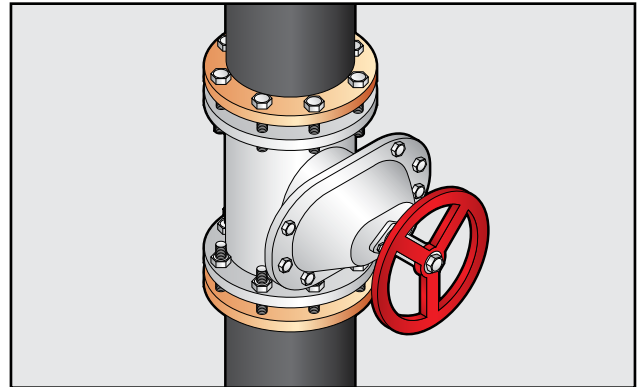

- **Note:** for chilled water or refrigeration systems, insert and glue strips of AEROFLEX insulation between flange bolts in valve body.

- Using caliper, measure circumference of insulated pipe and flange.

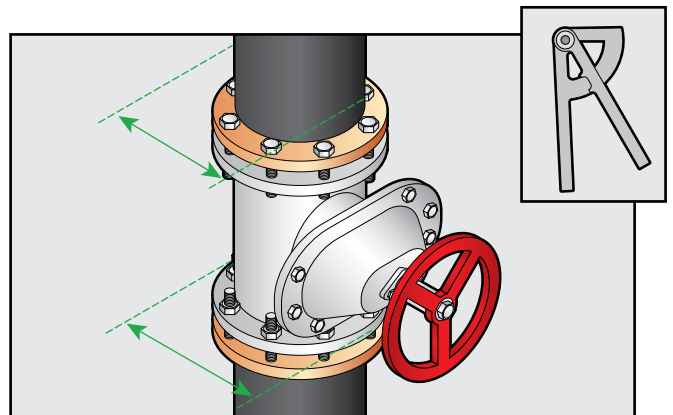

- Using divider, draw inner and outer circumferences on two separate pieces of AEROFLEX Sheet.

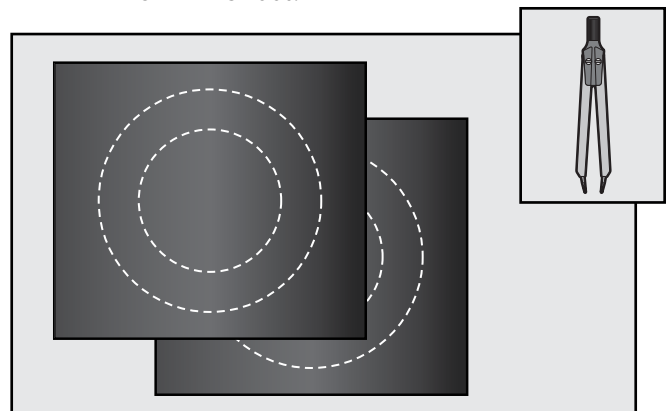

- Carefully cut out both rings and slit one side to wrap around flange.

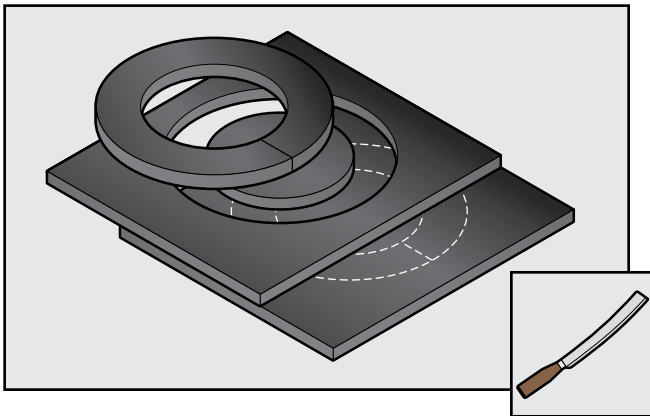

- Wrap rings around pipes on both sides of flange and fully adhere to insulation inserts and bolts at flange and insulated pipes.

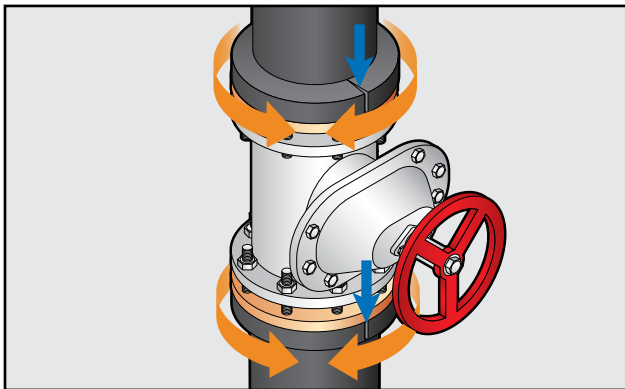

- Measure circumference of rings (C) with strip of AEROFLEX Sheet that is the same thickness (do not stretch); add 1/4" [.64 cm] to measurement.

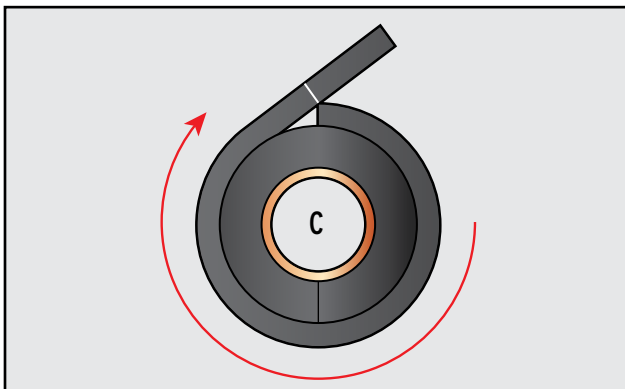

- Measure width of insulated valve including rings (W) and spindle housing (S).

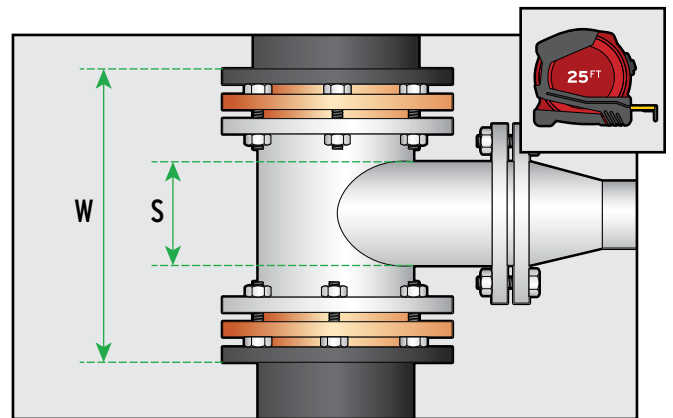

- On AEROFLEX Sheet, mark and cut width (W), ring circumference (C) and diameter of spindle (S); mark spindle cut-out 1/8"-1/4" [.32 cm -.64 cm] short for compression fit.

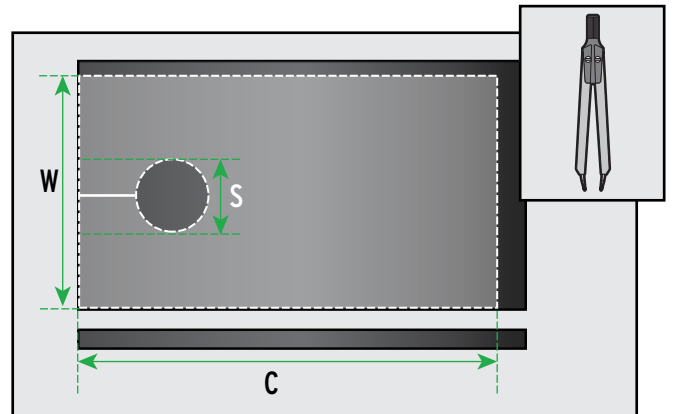

- Cut jacket and wrap around valve to ensure proper fit (not stretched).

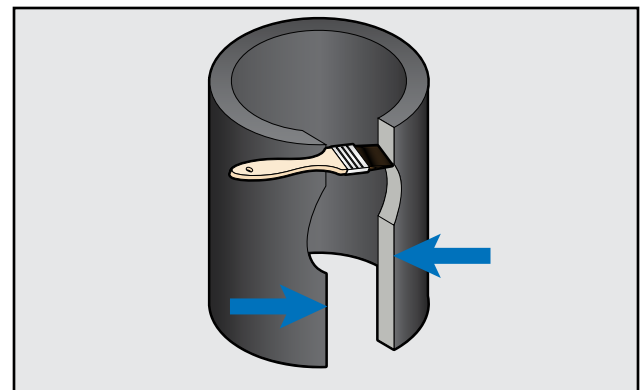

- Apply AEROFLEX adhesive to jacket seam, flange rings, spindle housing and allow to tack.

- When ready for contact, carefully adhere jacket to rings with flush edges under compression.

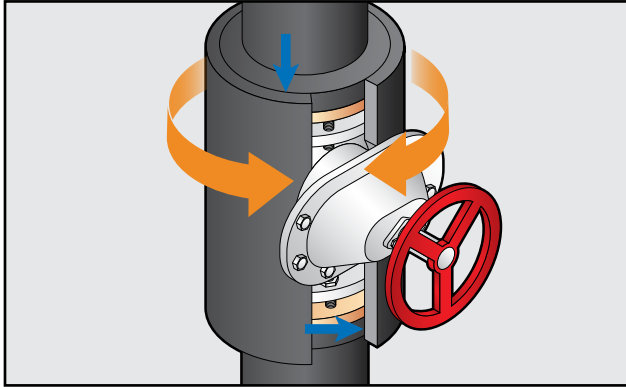

- Ensure complete vapor seal with no gaps present.
 - Optional: for interior installations, apply Protape over glued longitudinal seams, butt joints and fittings.
 - Required: for exterior installations, apply Protape over glued longitudinal seams, butt joints and fittings.
 - Optional (recommended): to maximize AEROFLEX life cycle for exterior applications, apply Aerocoat, Aerocoat LVOC or jacketing system for UV protection. For mechanical protection, install jacketing system specifically designed for pipe insulation.

• **Spindles**

- Measure height (H) and width (W) and shape of spindle housing.

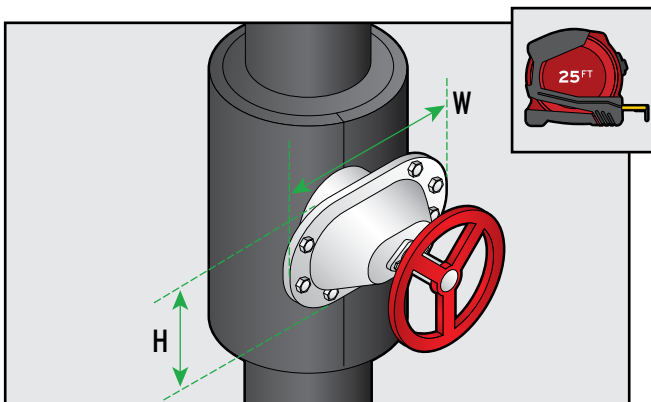

- Mark and cut insulation fitting for face plate of spindle flange from AEROFLEX Sheet.

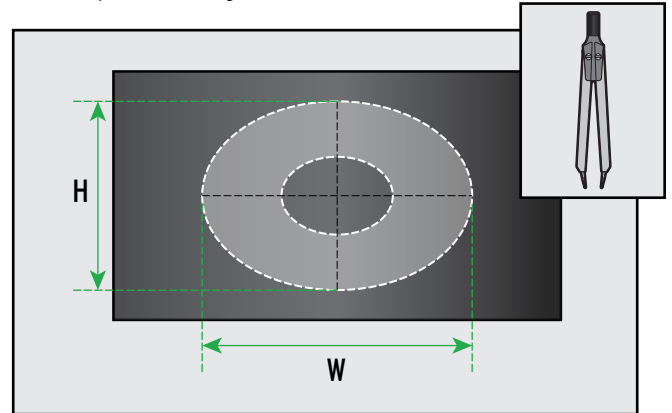

- Cut one side of insulation fitting, glue edges with AEROFLEX adhesive and allow to tack.
- Once ready for contact, wrap insulation fitting over spindle and press glued edges firmly together; be sure to glue inside seam of insulation fitting to spindle face plate for vapor seal.

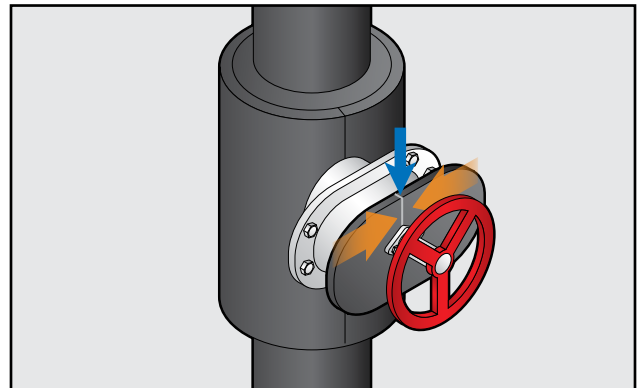

- Measure circumference (C) of insulation fitting with strip of AEROFLEX Sheet the same thickness (do not stretch); add 1/4" [.64 cm] to measurement.

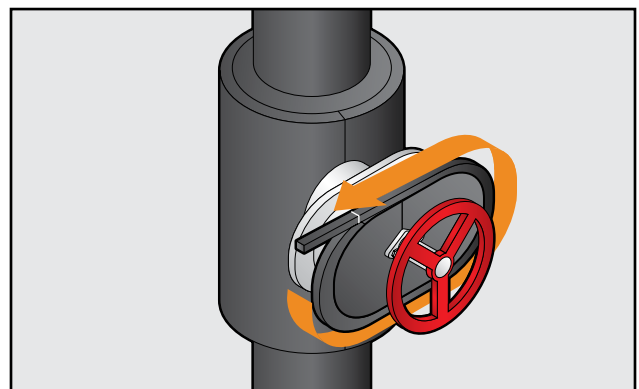

- On AEROFLEX Sheet (same thickness), lay circumferential strip on sheet and mark into 4 equal segments.

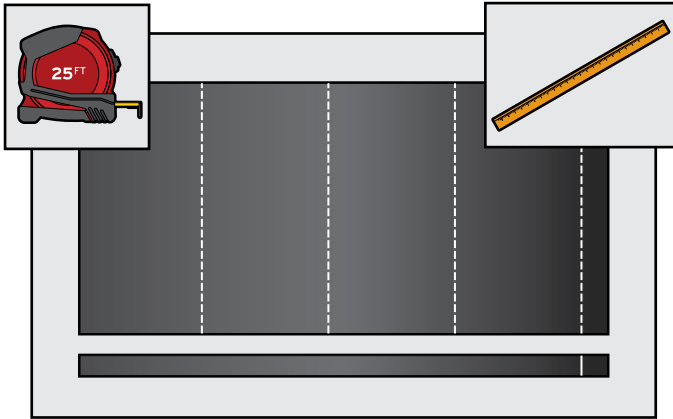

- Measure depth from outside edge of insulation fitting to nearest and farthest distance to valve body.

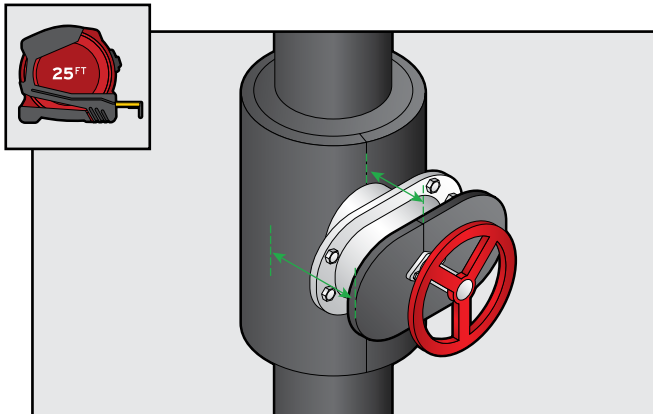

- Transfer both depth measurements to marked sheet.

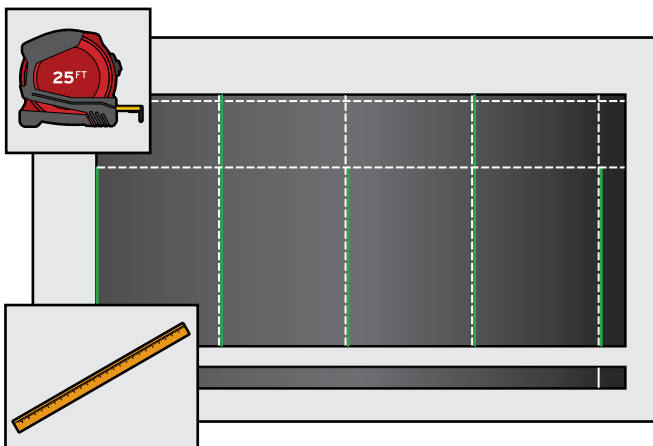

- Using divider with radius equaling difference between long and short measurements, draw intersecting arcs to create continuous line across 4 segments on sheet.

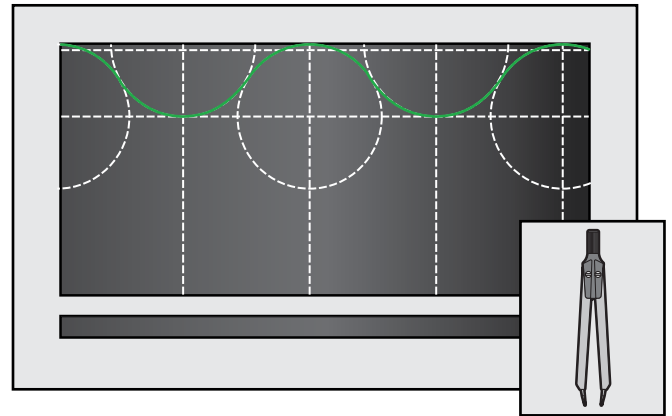

- Carefully cut along continuous line.

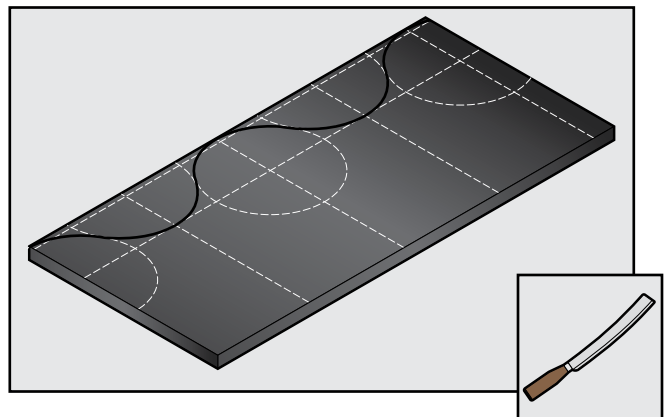

- Miter inside edge that will join valve body.

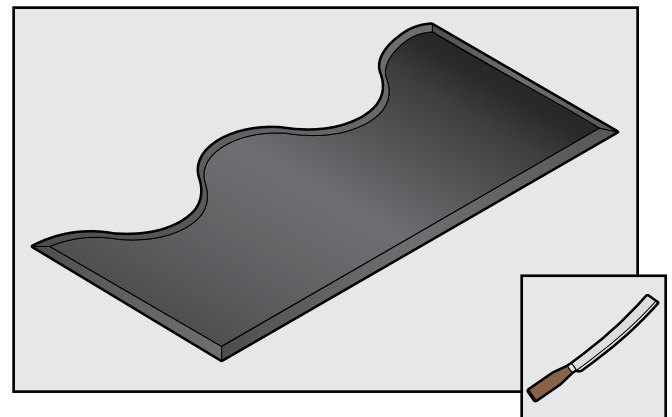

- Apply AEROFLEX adhesive to longitudinal seam, allow to tack and seal around spindle housing.

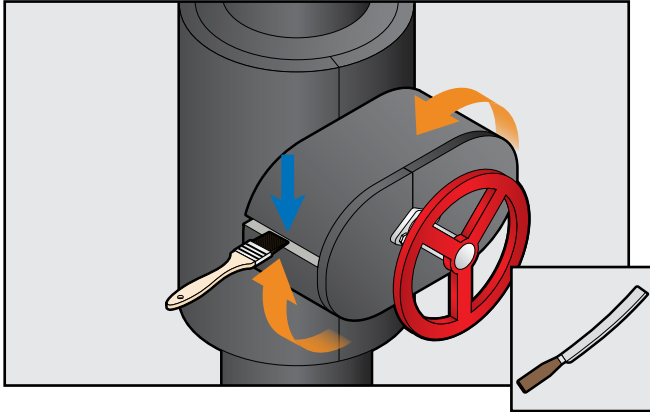

- Glue edges of spindle housing jacket to valve cover body with AEROFLEX adhesive under compression.

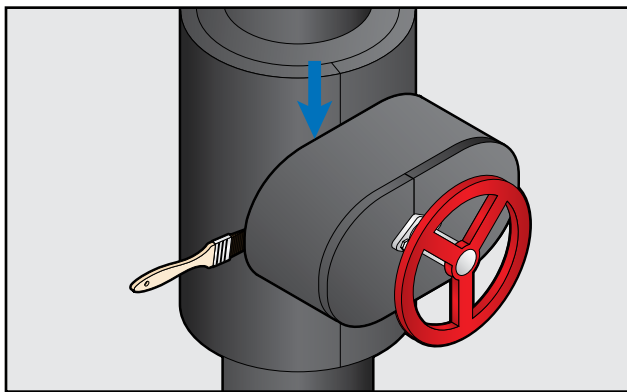

- Glue edges of spindle housing jacket to face plate cover with AEROFLEX adhesive under compression.

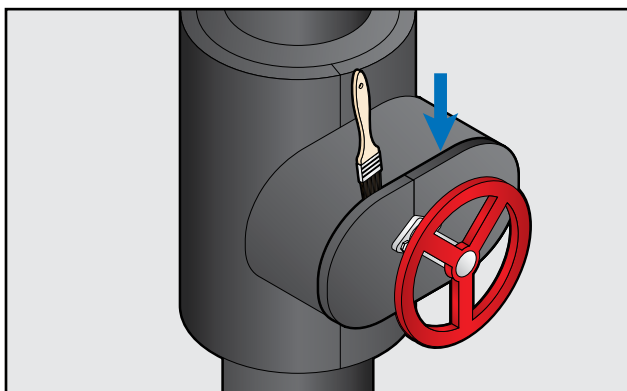

- Ensure complete vapor seal with no gaps present.
 - Optional: for interior installations, apply Protape over all glued spindle insulation fitting seams.
 - Required: for exterior and extreme installations, apply Protape over all spindle insulation fitting seams.
 - Optional (recommended): to maximize AEROFLEX life cycle for exterior applications, apply Aerocoat, Aerocoat LVOC or jacketing system for UV protection. For mechanical protection, install jacketing system specifically designed for pipe insulation.

- **Angled | Inclined Seat | Strainer Valves**

• **Body**

- Insulate adjoining pipes up to flange; valve body should always be insulated after piping.

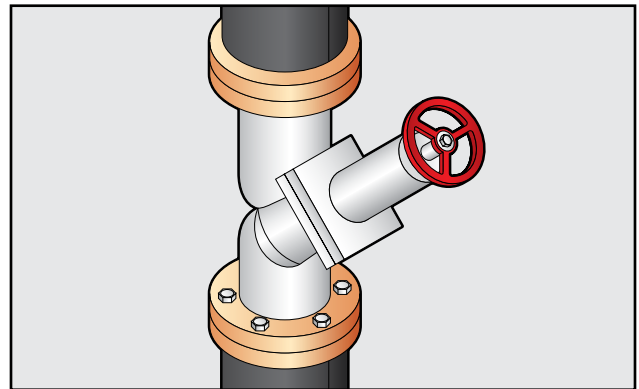

- **Note:** For chilled water or refrigeration systems, insert and glue strips of AEROFLEX insulation between flange bolts in valve body.

- Using caliper, measure circumference of insulated pipe (P) and flange (F).

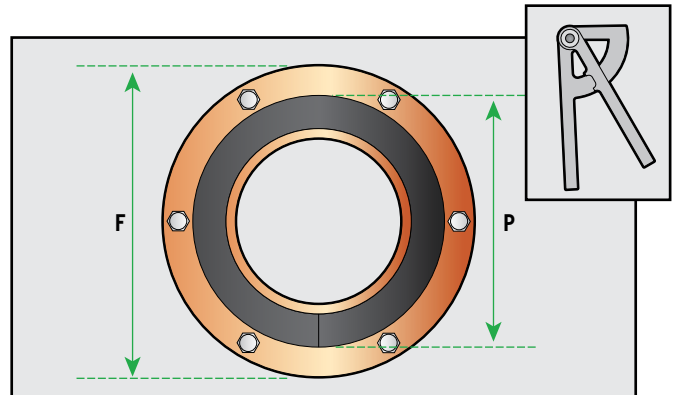

- Using divider, draw inner and outer circumferences on two separate pieces of AEROFLEX Sheet.

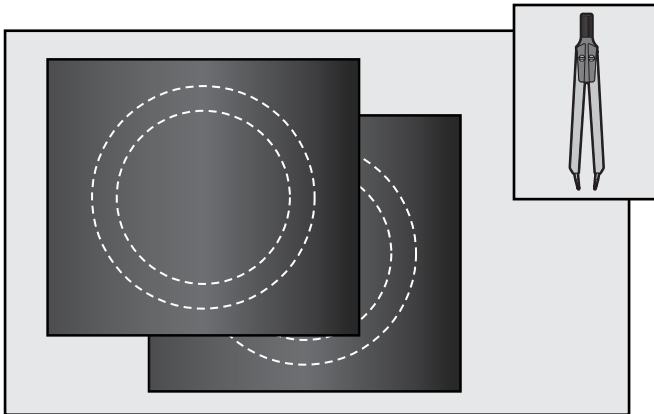

- Measure circumference of rings with strip of AEROFLEX Sheet that is the same thickness (do not stretch); add 1/4" [.64 cm] to measurement.

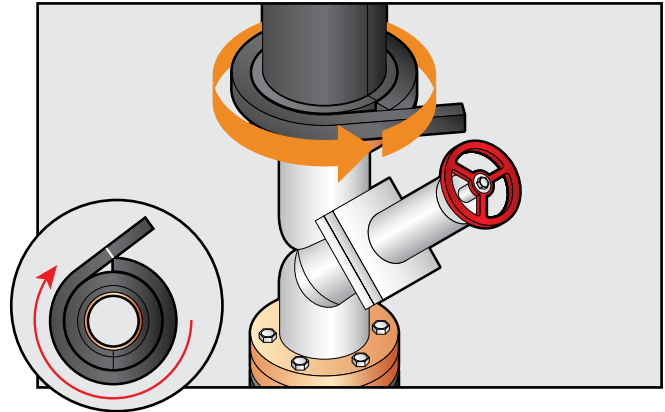

- Carefully cut out both rings and slit one side to wrap around flange.

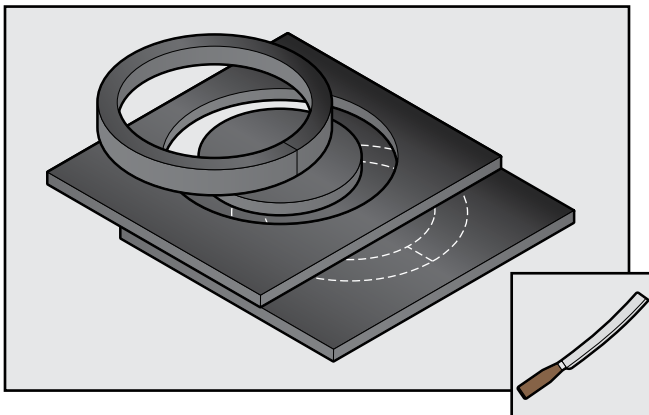

- Measure length between outer edges of each ring (S1, S2+S3) and strainer body.

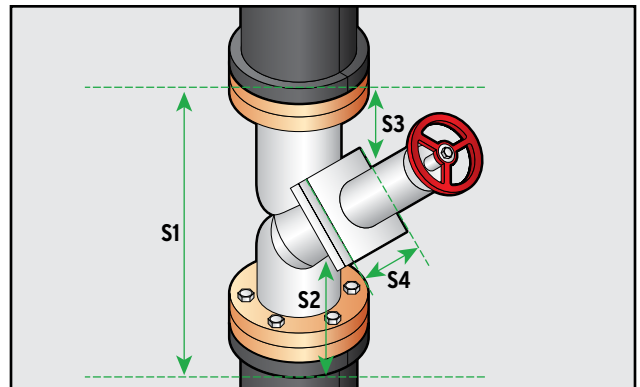

- Wrap rings around pipes on both sides of flange and fully adhere to insulation inserts and bolts at flange and insulated pipes with AEROFLEX adhesive.

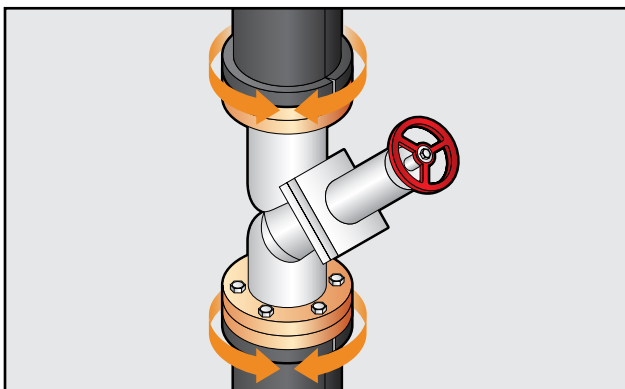

- Using caliper, measure diameter of strainer body (S).

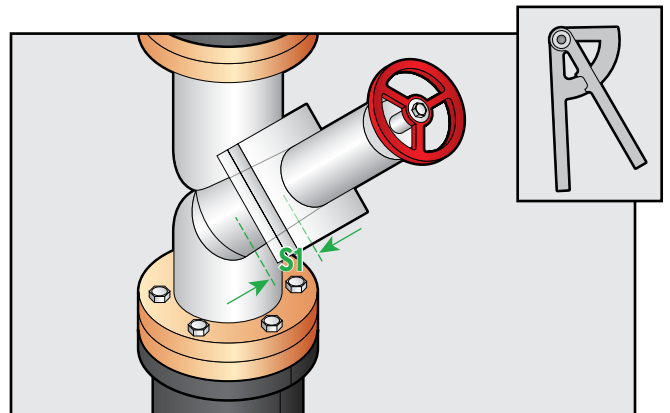

- Transfer above measurements to AEROFLEX sheet and mark sheet accordingly.

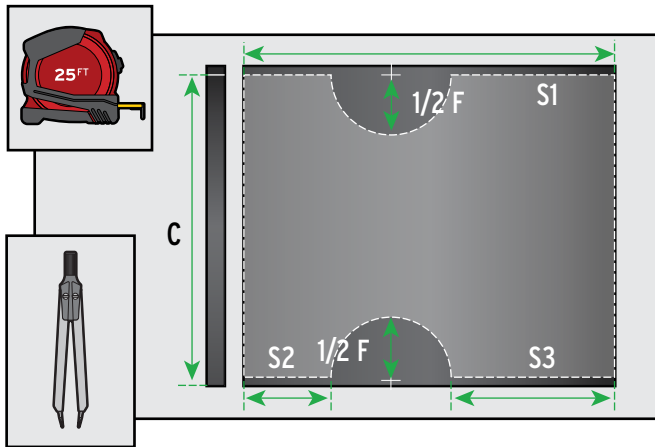

- Cut sheet along marked lines and wrap fabricated insulation fitting around valve body to ensure an accurate fit (do not stretch).
- Glue valve body insulation fitting to rings, longitudinal seam and around strainer body with AEROFLEX adhesive under compression.

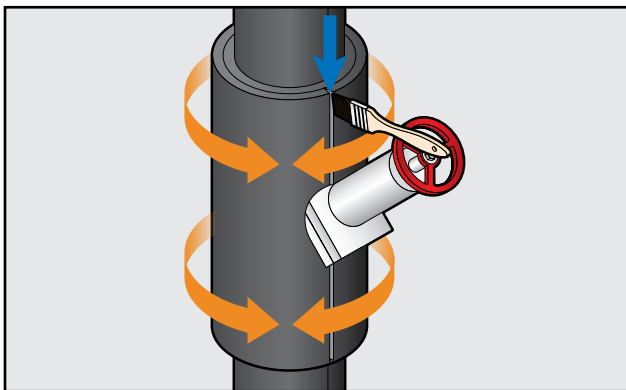

- Ensure complete vapor seal with no gaps present.
 - Optional: for interior installations, apply Protape over glued longitudinal seams, butt joints and strainer valve body seams.
 - Required: for exterior installations, apply Protape over glued longitudinal seams, butt joints and fittings.
 - Optional (recommended): to maximize AEROFLEX life cycle for exterior applications,

apply Aerocoat, Aerocoat LVOC or jacketing system for UV protection. For mechanical protection, install jacketing system specifically designed for pipe insulation.

• Strainer

- Using caliper & divider, measure diameter at end of strainer body, transfer measurements to AEROFLEX sheet of the same thickness, draw and cut ring to install at end of strainer. Glue ring to strainer with AEROFLEX adhesive.

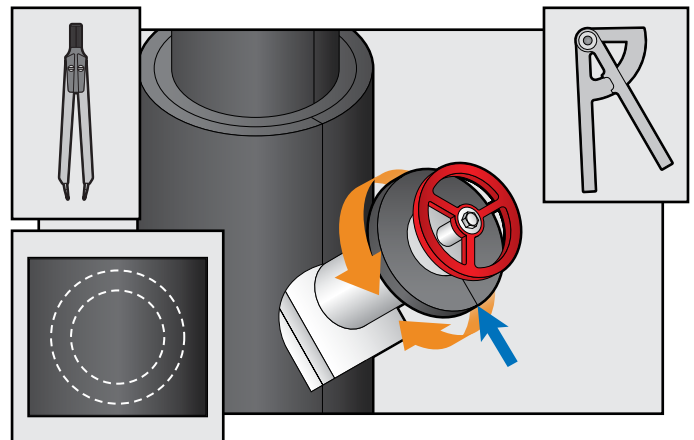

- Measure long (L) and short (S) sides of strainer body (including thickness of ring).

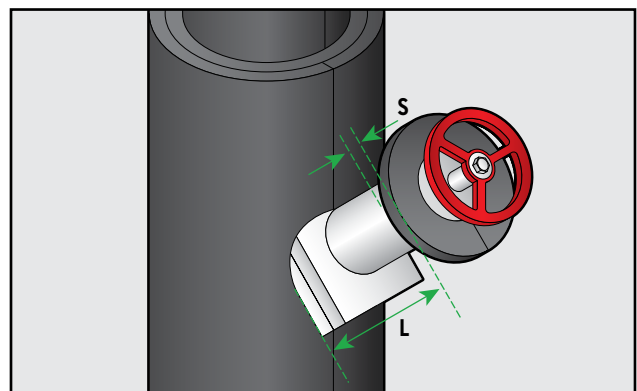

- Transfer measurement of 1/2 ring circumference (1/2 c) and inner/outer strainer dimensions to AEROFLEX Sheet of the same thickness.

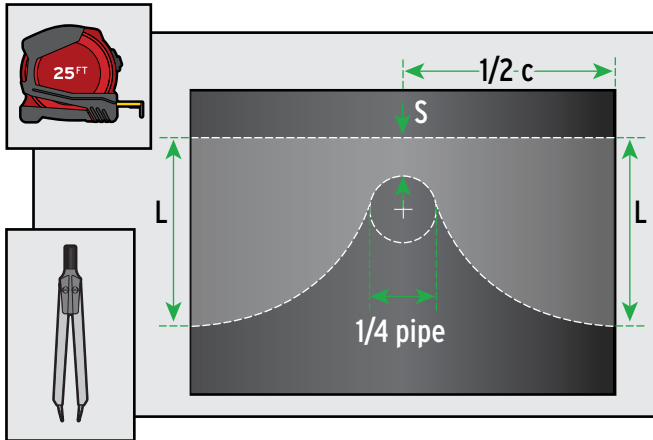

- Cut strainer insulation fitting along marked lines and miter inside edge to be adhered to strainer body to ensure flush fit (do not stretch).

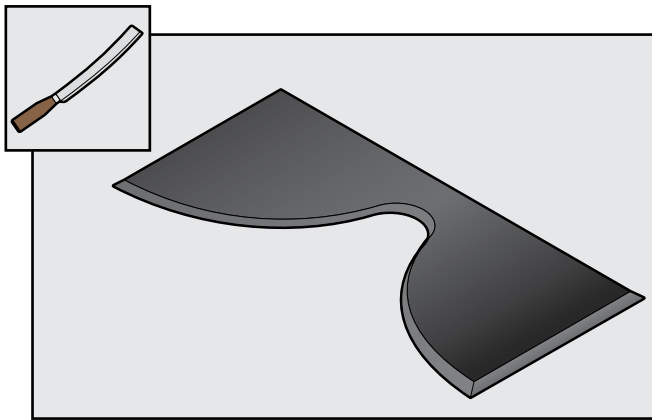

- Glue strainer body insulation fitting to rings, longitudinal seam and around strainer wheel with AEROFLEX adhesive under compression.

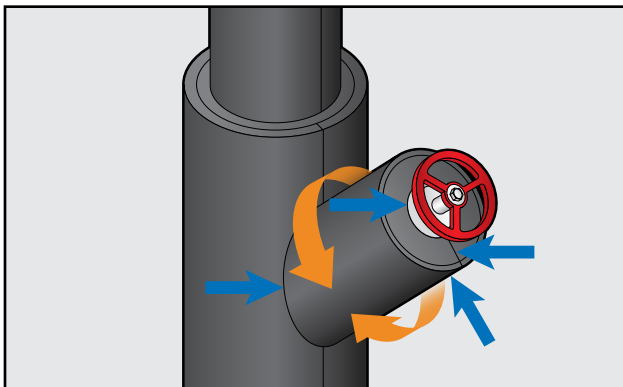

- Ensure complete vapor seal with no gaps present.
 - Optional: for interior installations, apply Protape over all glued strainer insulation fitting seams.
 - Required: for exterior and extreme installations, apply Protape over all strainer insulation fitting seams.
 - Optional (recommended): to maximize AEROFLEX life cycle for exterior applications, apply Aerocoat, Aerocoat LVOC or jacketing system for UV protection. For mechanical protection, install jacketing system specifically designed for pipe insulation.

- Pumps

- **Note:** Due to the wide variety of pump configurations, apply general fabrication principals with other insulation fitting types, primarily no gaps, proper adhesion and complete vapor seals at all insulation seams and terminations with AEROFLEX adhesive.

- Couplings

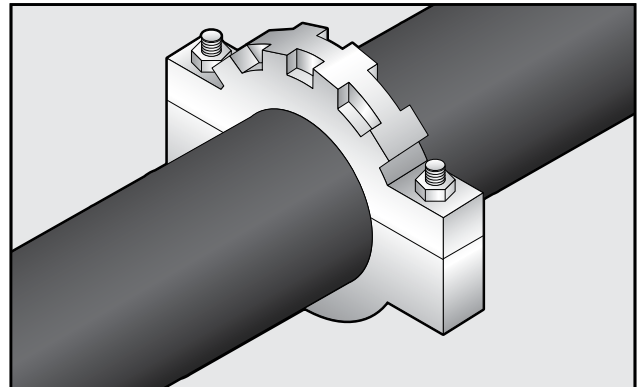

- Insulate adjoining pipes up to coupling.
- Measure dimensions of coupling.

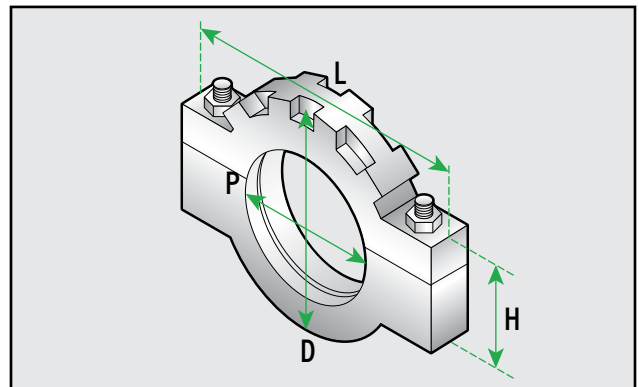

- Pipe (P) = outside diameter
- Length (L) = end-to-end
- Height (H) = height of screws plus 2x insulation thickness
- Diameter (D) = outside diameter
- Radius (R) = $D \times 1/2 + 2x$ insulation thickness
- Using divider, mark circular arc (P) and (D), length (L), height (H) and center line to AEROFLEX Sheet of the same thickness.

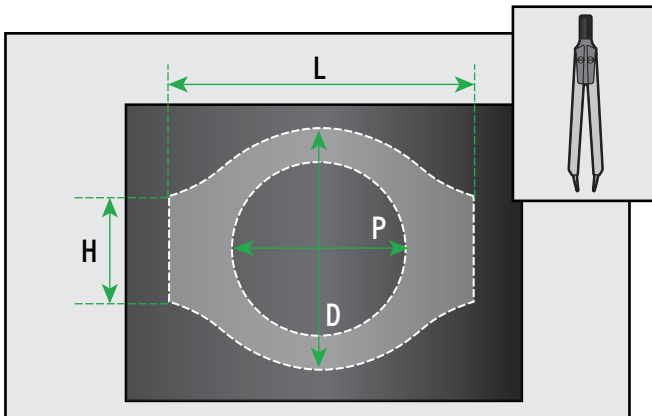

- Create oval shape by connecting circular arc and four points (coupling ring).
- Cut out this ring to use as template to duplicate a second coupling ring.
- Glue rings to both sides of coupling and pipe insulation with AEROFLEX adhesive.
- Measure width (X) and circumference of outer edges of rings with strip of AEROFLEX Sheet of the same thickness (do not stretch); add 1/4" [.64 cm] to measurement.

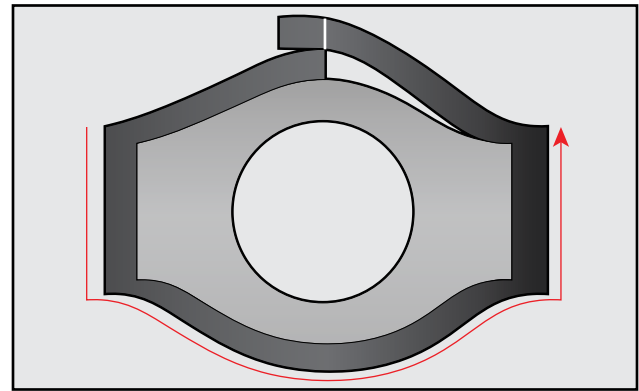
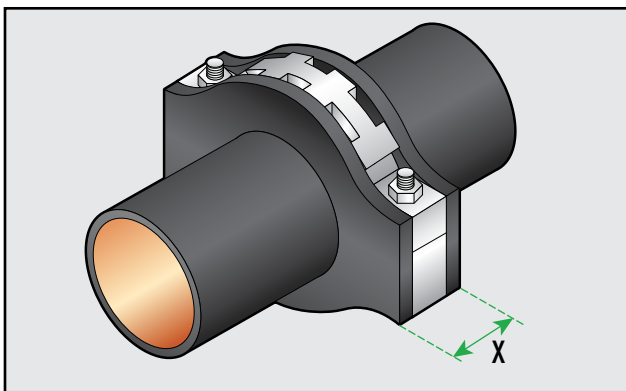

- Transfer these measurements to AEROFLEX Sheet of same thickness and cut out the coupling insulation fitting.
- Glue coupling insulation fitting to rings and insulation fitting seam with AEROFLEX adhesive under compression.

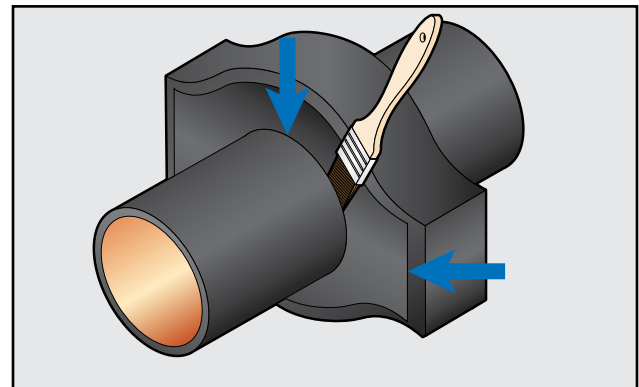

- Ensure complete vapor seal with no gaps present.
- Optional: for interior installations, apply Protape over all glued coupling insulation fitting seams.
- Required: for exterior and extreme installations, apply Protape over all coupling insulation fitting seams.
- Optional (recommended): to maximize AEROFLEX life cycle for exterior applications, apply Aerocoat, Aerocoat LVOC or jacketing system for UV protection. For mechanical protection, install jacketing system specifically designed for pipe insulation.

PIPE SUPPORTS | AEROFIX®



- Pipe hangers can apply to all pipe sizes.
- **Distance between hangers not to exceed 10 feet (3 m) when installing Aerofix.**
- **Clevis and Similar Pipe Hangers**
 - Open Aerofix fitting, remove two inside release liners, wrap around pipe, and press two halves together.
 - Adjust Aerofix seams so they are set at 9 o'clock and 3 o'clock positions on pipe, bottom of hanger at 6 o'clock position.

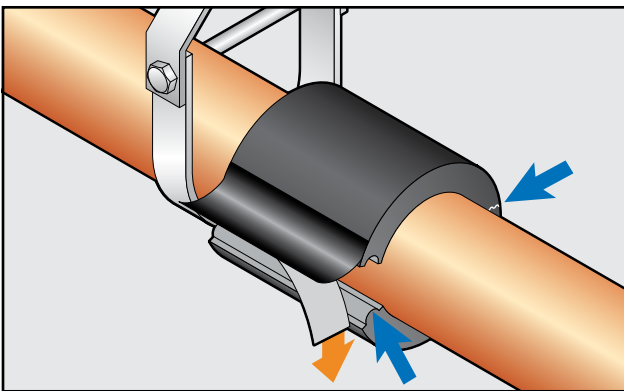

- Remove release liner from Protape outer jacket and apply with pressure to achieve a vapor seal.

- Slide Aerofix into center of hanger.

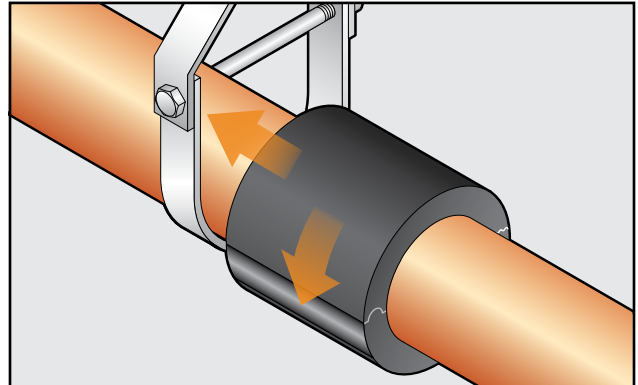

- Seal Aerofix to adjoining AEROFLEX pipe insulation with AEROFLEX adhesive and apply firm pressure under compression.

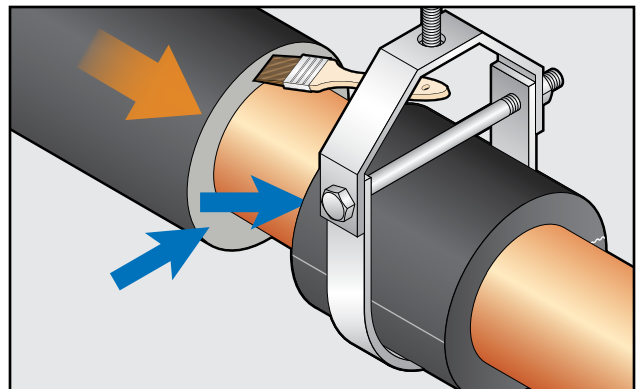

- Seams between adjoining pipe insulation and pipe support must be completely sealed with AEROFLEX adhesive to prevent thermal bridging and corrosion under insulation (CUI).

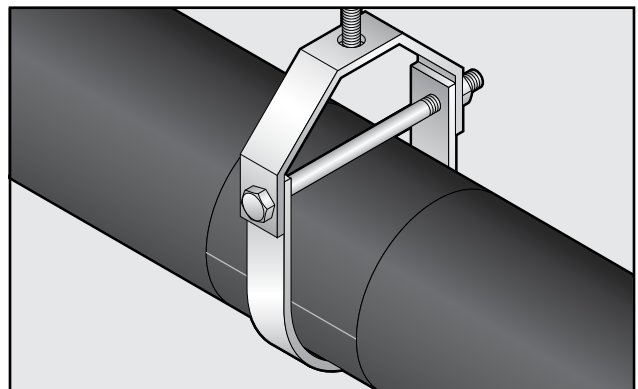

- Insulation saddles/shields can be installed in clevis hangers when there is a concern with linear movement of pipe supports on dynamic piping systems.

- Saddle/Shield type and size to be determined by the project engineer or contractor.
- Optional: for systems operating above -20°F [-29°C], apply Protape over glued seams.
- **Required: for systems operating below -20°F [-29°C], apply Protape over glued seams.**
- Optional (recommended): to maximize AEROFLEX life cycle for exterior applications, apply Aerocoat, Aerocoat LVOC or jacketing system for UV protection. For mechanical protection, install jacketing system specifically designed for pipe insulation.

- Struts With Clamps

- This application typically involves copper pipe sizes up to 4-1/8" ID.
- **Distance between struts not to exceed 10 feet (3 m) when installing Aerofix.**
- For more information about struts and clamps, visit Wesanco-ZSI at: <https://www.zsiinc.com/our-catalog.html>



- Open Aerofix fitting, remove two inside release liners, wrap around pipe, and press two halves together.

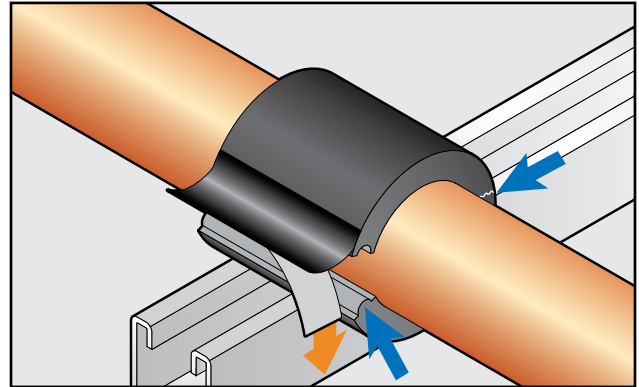

- Adjust Aerofix seams so they are set at 9 o'clock and 3 o'clock positions on pipe, strut at 6 o'clock position.
- Remove release liner from Protape outer jacket and apply with pressure to achieve a vapor seal.
- Center Aerofix on strut and install clamp.

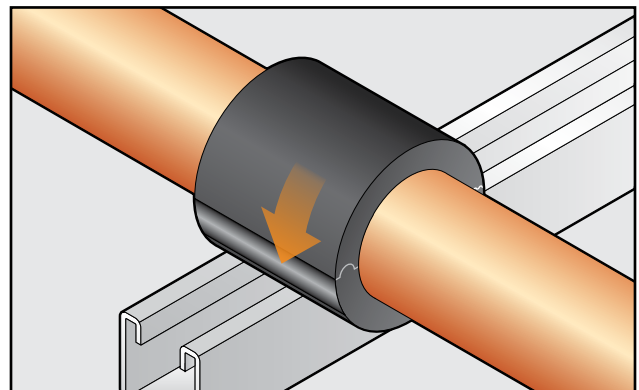

- Seal Aerofix to adjoining AEROFLEX pipe insulation with AEROFLEX adhesive and apply firm pressure under compression.

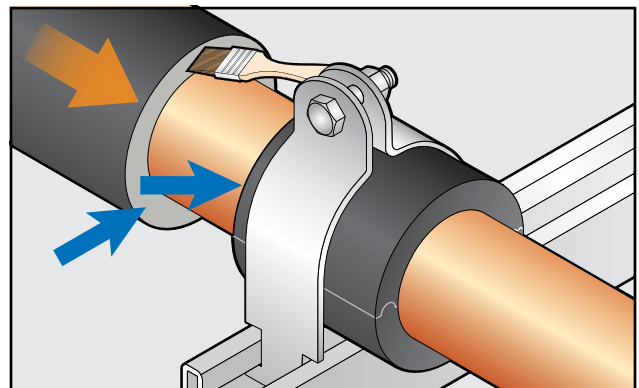

- Seams between adjoining pipe insulation and pipe support must be completely sealed with AEROFLEX adhesive to prevent thermal bridging and corrosion under insulation (CUI).

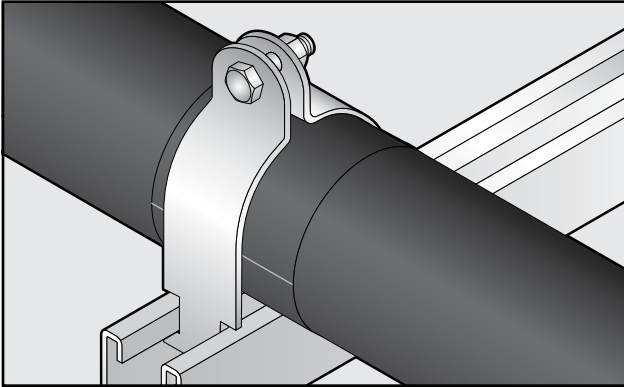

- Optional: for systems operating above -20°F [-29°C], apply Protape over glued seams.
- **Required: for systems operating below -20°F [-29°C], apply Protape over glued seams.**
- Optional (recommended): to maximize AEROFLEX life cycle for exterior applications, apply Aerocoat, Aerocoat LVOC or jacketing system for UV protection. For mechanical protection, install jacketing system specifically designed for pipe insulation.

- Struts | Pipe Stands with Saddles/Shields



- **Saddles/Shields must be installed under Aeroflex on struts to disperse point load for pipe sizes 4-1/2" (4" IPS) and larger.**

- Saddle/shield type and size to be determined by the project engineer or contractor.
- **Distance between struts/pipe stands not to exceed 10 feet (3 m) when installing Aerofix.**
- For more information about insulation saddles/shields, visit Wesanco-ZSI at: <https://www.zsiinc.com/our-catalog.html>
- Open Aerofix fitting, remove two inside release liners, wrap around pipe, and press two halves together.
- Adjust Aerofix seams so they are set at 9 o'clock and 3 o'clock positions on pipe, saddles/shields at 6 o'clock position.

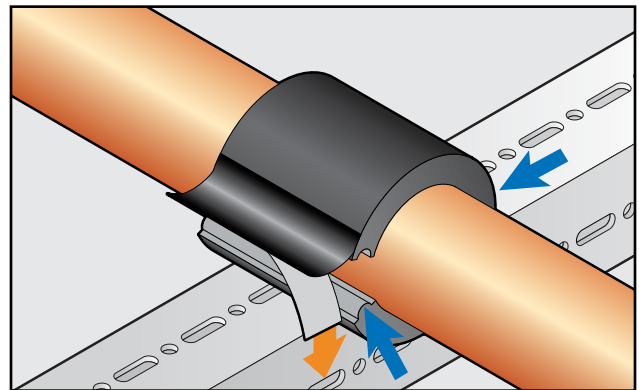

- Remove release liner from Protape outer jacket and apply with pressure to achieve a vapor seal.
- Center Aerofix on strut.

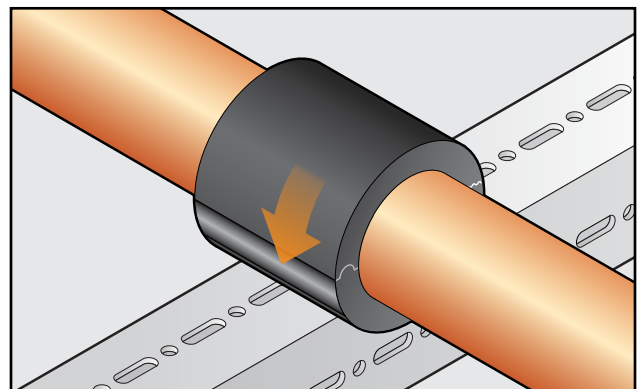

- Seal Aerofix to adjoining AEROFLEX pipe insulation with AEROFLEX adhesive and apply firm pressure under compression.

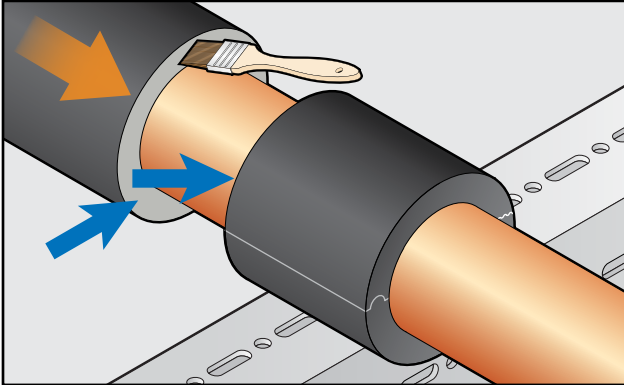

- Install saddle/shield under insulated pipe on strut.
- Seams between adjoining pipe insulation and pipe support must be completely sealed to prevent thermal bridging and corrosion under insulation (CUI).

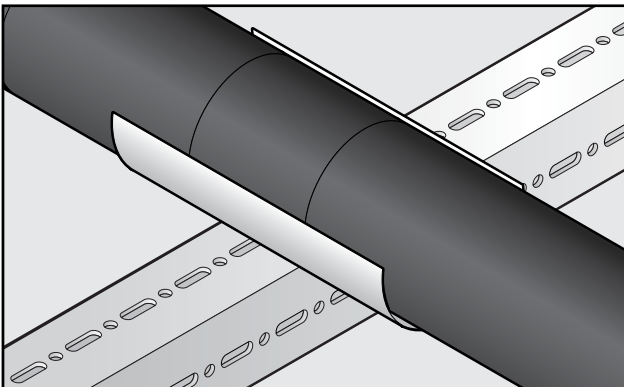

- Optional: for systems operating above -20°F [-29°C], apply Protape over glued seams.
- **Required: for systems operating below -20°F [-29°C], apply Protape over glued seams.**
- Optional (recommended): to maximize AEROFLEX life cycle for exterior applications, apply Aerocoat, Aerocoat LVOC or jacketing system for UV protection. For mechanical protection, install jacketing system specifically designed for pipe insulation.

- Vertical Riser Clamps

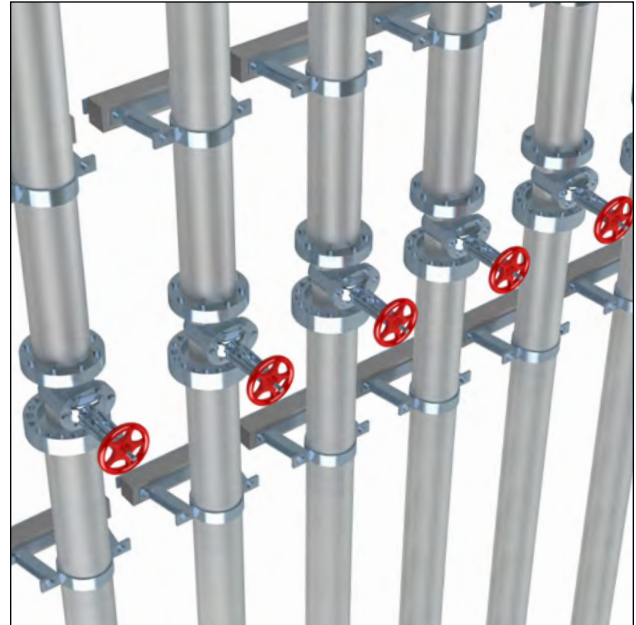

- Open Aerofix fitting, remove two inside release liners, wrap around pipe, and press two halves together.
- Adjust Aerofix seams so they are set parallel with riser clamps.

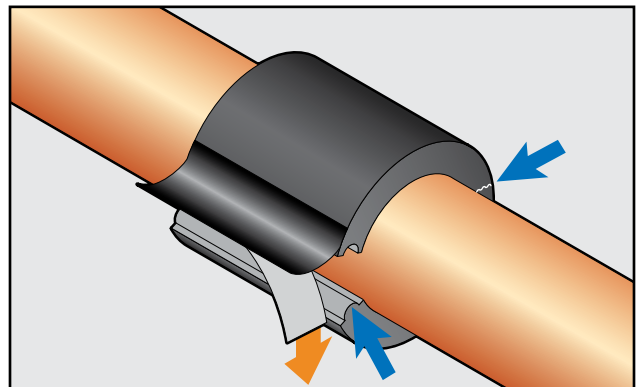

- Remove release liner from Protape outer jacket and apply with pressure to achieve a vapor seal.

- Center Aerofix in riser clamps.

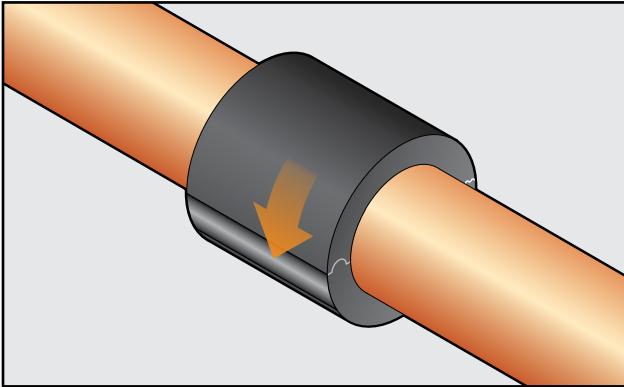

- Create vapor dam on both sides of each AEROFIX pipe support by bonding adjoining insulation tubes directly to the pipe with AEROFLEX adhesive; width of vapor dam should be equal to insulation thickness.
- Seal Aerofix to adjoining AEROFLEX pipe insulation with AEROFLEX adhesive and apply firm pressure under compression.

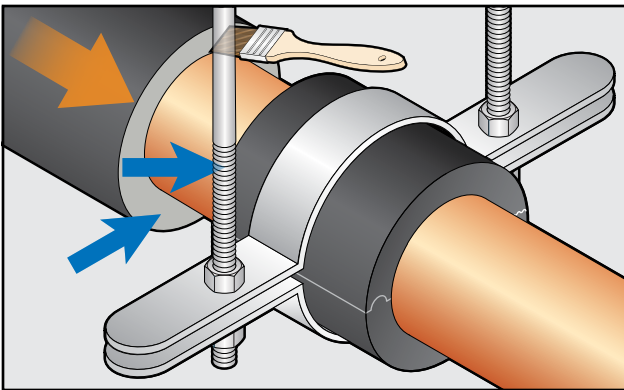

- Seams between adjoining pipe insulation and pipe support must be completely sealed with AEROFLEX adhesive to prevent thermal bridging and corrosion under insulation (CUI).

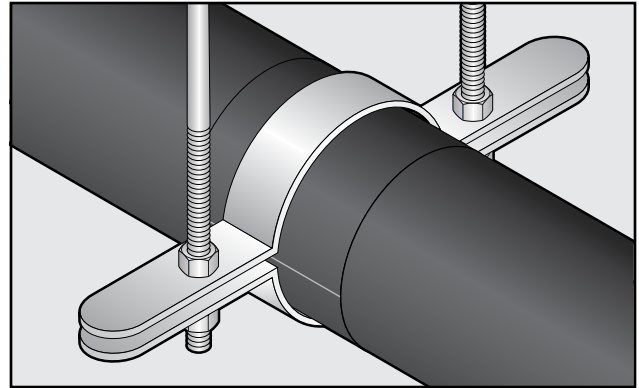

- Optional: for systems operating above -20°F [-29°C], apply Protape over glued seams.
- **Required: for systems operating below -20°F [-29°C], apply Protape over glued seams.**
- Optional (recommended): to maximize AEROFLEX life cycle for exterior applications, apply Aerocoat, Aerocoat LVOC or jacketing system for UV protection. For mechanical protection, install jacketing system specifically designed for pipe insulation.

- Insulate up to calcium silicate or phenolic supports

- **Note:** not an ideal system since two different insulation materials are installed through pipe hanger/strut.
- Clean all pipe support surfaces with denatured alcohol.
- Apply thin primer coat of AEROFLEX adhesive to pipe support and allow to dry.
- Apply 2nd coat of AEROFLEX adhesive to pipe support and adjoining AEROFLEX insulation tubes; allow to tack up until ready for contact.
- Bond insulation to both sides of pipe support under compression.
- Ensure that entire pipe support is insulated and glued to provide vapor seal and prevent thermal bridging (condensation).
- Cover all glued seams and terminations with Protape.

TANKS & VESSELS



- Surface Preparation

- Clean and dry tank/vessel surface to remove bond-breaking agents (grease, oil & water) and contaminants that could cause bond failure and/or corrosion under insulation.
- **Note:** When using an aerosolized spray contact adhesive, confirm with manufacturer that adhesive is recommended for bonding closed cell flexible elastomeric foam insulation to tanks/vessels and follow application instructions.

- AEROFLEX Sheet & Roll with AEROFLEX adhesive

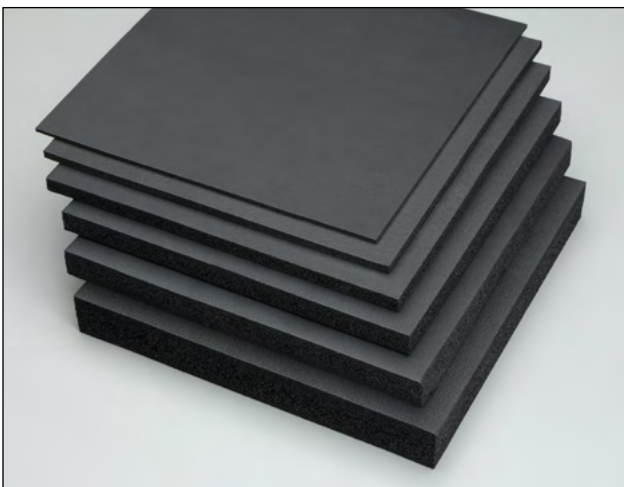

- **Follow AEROFLEX adhesive best practices** and adjust depending on jobsite conditions (ambient temperature, direct sun and relative humidity).
- Apply AEROFLEX adhesive to insulation and tank/vessel with adhesive roller and allow to tack dry to the touch without transfer.
- Ensure full contact of glued insulation to glued tank/vessel surface with weighted roller.
- Glue all adjoining seams and termination points with AEROFLEX adhesive under compression to create vapor seal.
- To meet low-VOC requirements, select AEROFLEX Sheet & Roll with PSA and AeroSeal LVOC Black adhesive to seal all seams and termination points.
 - Optional: for interior installations, apply Protape over glued seams.
 - Required: for exterior installations, apply 2" Protape evenly over seams followed by 2" on either side of taped seam (4" [10 cm] total taped seam width).
 - Optional (recommended): to maximize AEROFLEX life cycle for exterior applications, apply AeroCoat, AeroCoat LVOC or jacketing system for UV protection. For mechanical protection, install jacketing system specifically designed for tank/vessel insulation.

- AEROFLEX Sheet/Roll with PSA



- Peel PSA release liner and adhere AEROFLEX insulation directly to clean tank/vessel surface.

- Use weighted roller to activate and ensure full contact of PSA adhesive on insulation sheet/roll to tank/vessel.
- Glue all adjoining seams and termination points with AEROFLEX adhesive under compression to create vapor seal.
 - Optional: for interior installations, apply Protape over glued seams.
 - Required: for exterior installations, apply 2" Protape evenly over seams followed by 2" on either side of taped seam (4" [10 cm] total taped seam width).
 - Optional (recommended): to maximize AEROFLEX life cycle for exterior applications, apply Aerocoat, Aerocoat LVOC or jacketing system for UV protection. For mechanical protection, install jacketing system specifically designed for tank/vessel insulation.

- Small (< 5' diameter)

- Measure the circumference of the tank using a strip of AEROFLEX Sheet insulation of same thickness. Adhere strips together if necessary (do not stretch); add 1/4" [.64 cm] to measurement.

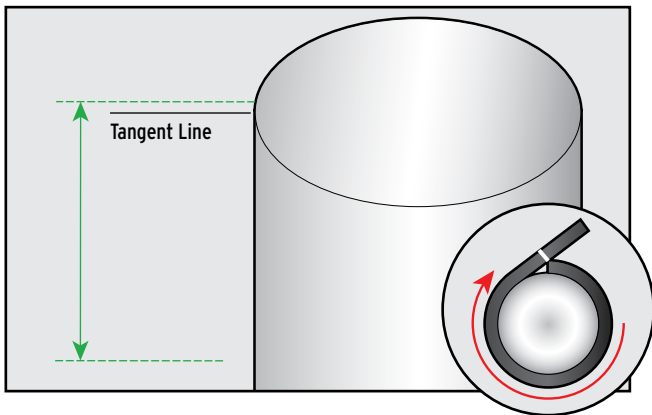

- Transfer this measurement to AEROFLEX Sheet, mark and cut length with straight edge.
- Starting from the top where the dome meets the body, install insulation approximately 2" [5 cm] above tank body for compression fit with dome insulation.
- Follow adhesive/PSA installation guidance above.

- Continue to install insulation horizontal courses to bottom of tank/vessel ensuring that insulation is installed under compression.
- Glue vertical seam under compression with AEROFLEX adhesive.

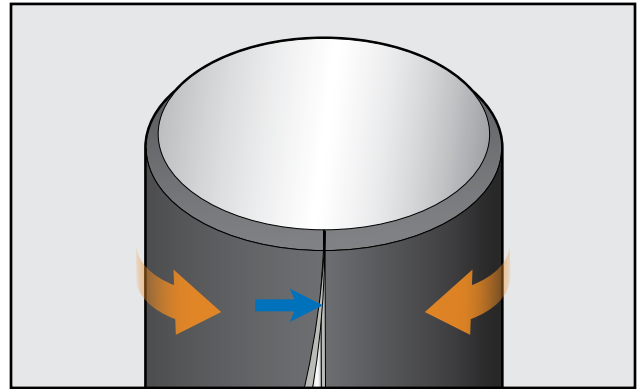

- Measure the diameter of the dome using a strip of AEROFLEX Sheet insulation of same thickness. Adhere strips together if necessary (do not stretch); add 1/4" [.64 cm] to measurement.

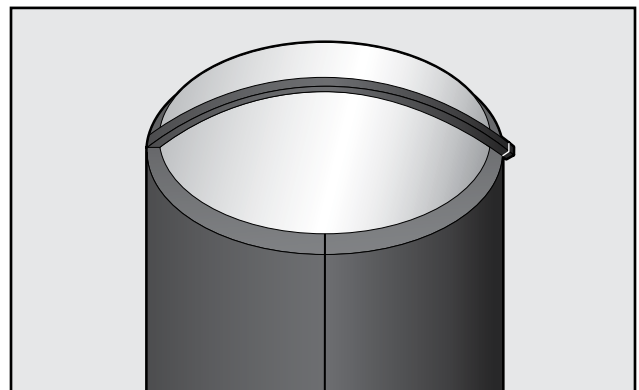

- Transfer diameter measurement to AEROFLEX Sheet, draw radius and then circumference.

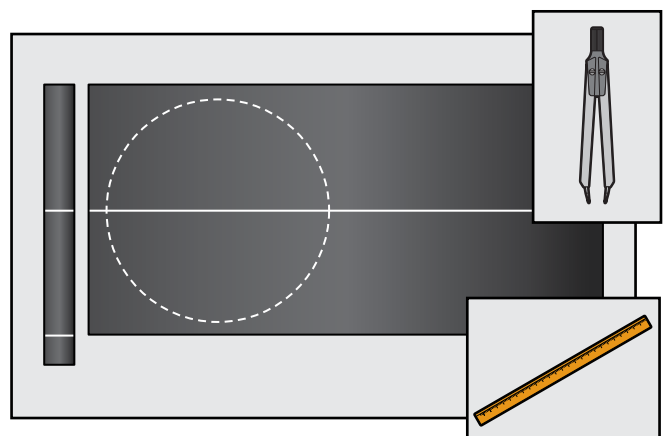

- Cut out dome cover. If necessary, glue multiple sheets together for dome cover.

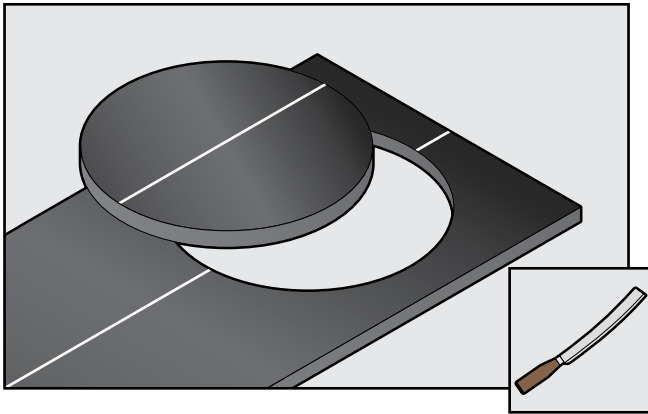

- Apply AEROFLEX adhesive to both surfaces and allow to tack.

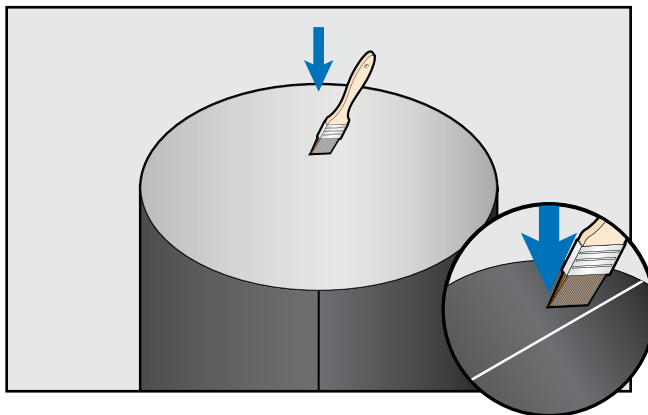

- When adhesive is ready for contact, apply to dome pressing down firmly from the center to outer edges.

- For both full-coverage adhesive and PSA applications, seal all seams and terminations on dome and body with AEROFLEX adhesive under compression to provide vapor seal.

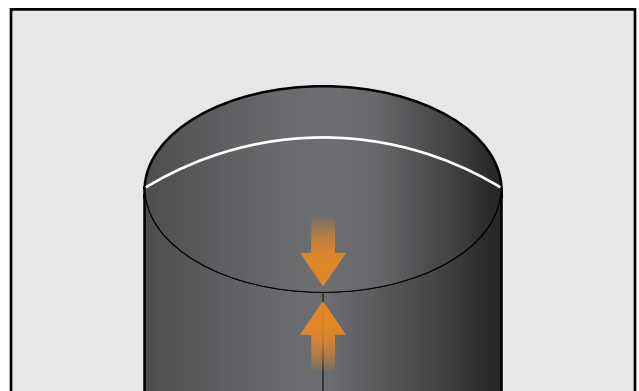
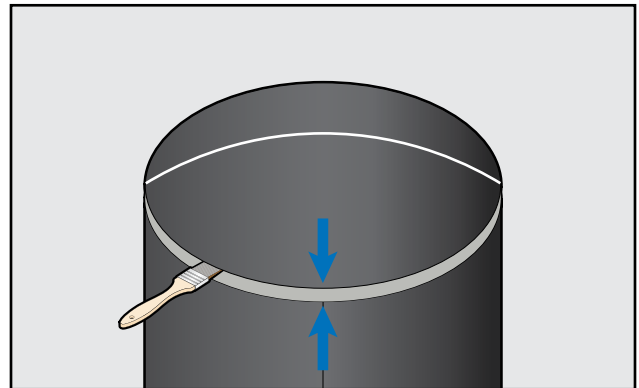
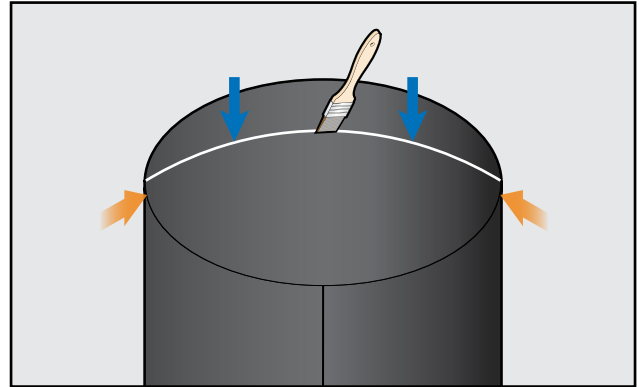

- Optional: for interior installations, apply Protape over all glued dome cover and body seams.
- Required: for exterior and extreme installations, apply 2" Protape evenly over seams followed by 2" on either side of taped seam (4" [10 cm] total taped seam width).

- Optional (recommended): to maximize AEROFLEX life cycle for exterior applications, apply Aerocoat, Aerocoat LVOC or jacketing system for UV protection. For mechanical protection, install jacketing system specifically designed for tank/vessel insulation.

- Large (> 5' diameter)

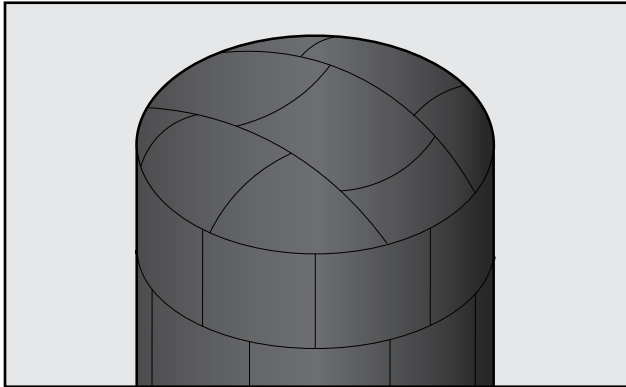

- Starting from the top of the tank/vessel where the dome meets the body, install insulation approximately 2" [5 cm] above tank body for compression fit with dome insulation.
- Glue vertical and horizontal seams under compression with AEROFLEX adhesive.

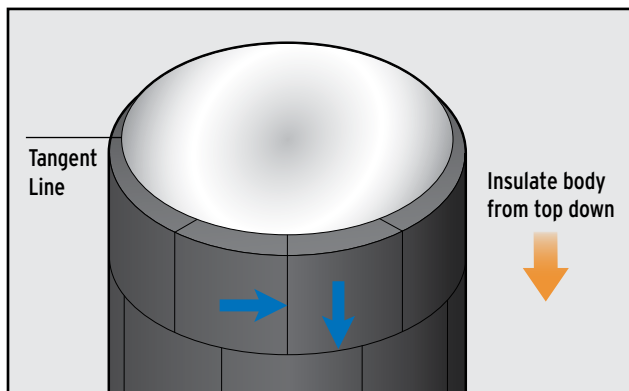

- Follow adhesive/PSA installation guidance above.
- Continue to install insulation horizontal courses under compression to bottom of tank/vessel.

- To fabricate dome cover, first mark top insulation edges of tank/vessel body that intersect dome with chalk.

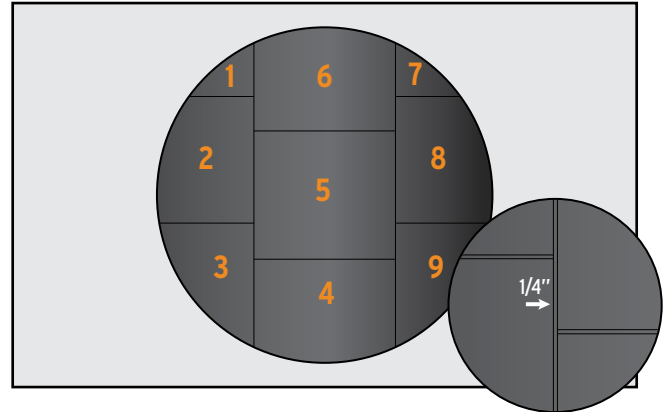

- Apply AEROFLEX Sheet over section to be insulated with 2" [5 cm] overlap and press into chalked edge to make impression on underside of insulation.
- Cut sheet with chalked outline.
- Apply AEROFLEX adhesive to cut sheets and dome, allow to tack and apply with firm pressure, working from the center to outer edges of each sheet; do not adhere to perimeter of body insulation yet.

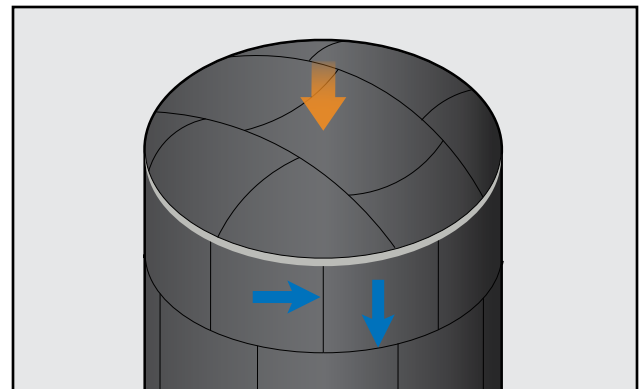

- Once all sections of the dome are insulated, glue perimeter seam with AEROFLEX adhesive under compression to create vapor seal.

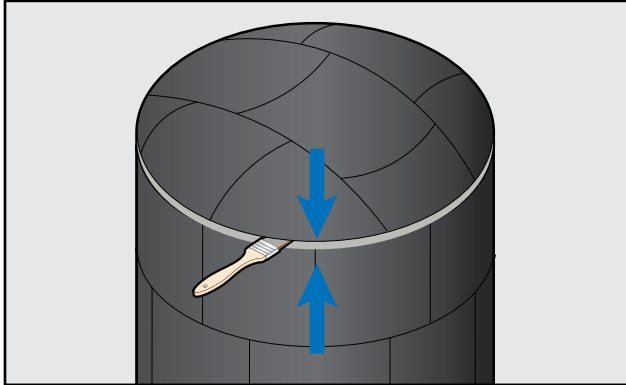

- For both full-coverage adhesive and PSA applications, seal all seams and termination points on dome and body with AEROFLEX adhesive under compression to provide vapor seal.
 - Optional: for interior installations, apply Protape over all glued dome cover and body seams.
 - Required: for exterior and extreme installations, apply 2" Protape evenly over seams followed by 2" on either side of taped seam (4" [10 cm] total taped seam width).
 - Optional (recommended): to maximize AEROFLEX life cycle for exterior applications, apply Aerocoat, Aerocoat LVOC or jacketing system for UV protection. For mechanical protection, install jacketing system specifically designed for tank/vessel insulation.

DUCT WRAP Interior | Exterior



- **Round Spiral (see pages 32-35)**
- **Rectangular**
 - **AEROFLEX Breathe-EZ Duct Insulation | AEROFLEX Adhesive**



- Thoroughly clean sheet metal surfaces to receive insulation with denatured alcohol to remove dust, oil or moisture.

• **Notes:**

- When using an aerosolized spray contact adhesive, confirm with manufacturer that adhesive is recommended for bonding closed cell flexible elastomeric foam insulation to sheet metal ductwork and follow application instructions.
- For exterior applications, horizontal rectangular ductwork must have a pitch on top side, as determined by HVAC designer, to allow for watershed to prevent ponding of water and ice.
- When jacketing Breathe-EZ for exterior applications, confirm with jacket manufacturer recommended jacket and tape overlap (when applicable) at sealed seams.
- For multi-layer applications, ensure that all 2nd-layer seams are staggered over 1st layer.
- Measure duct dimensions and cut Breathe-EZ with straight edge.

- **Note:** add 1/4" [.64 cm] to all measurements for compression-fitting seams (not stretched).

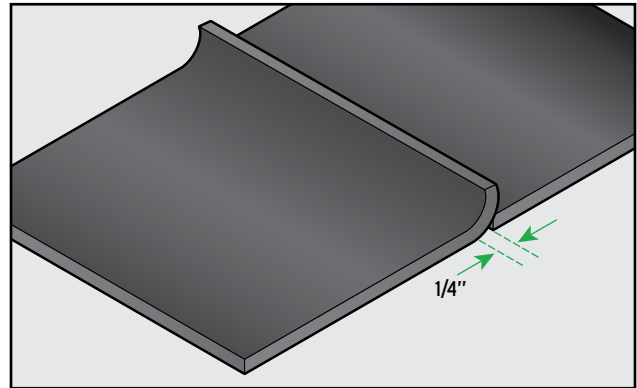

- Duct must be insulated in same sequence as measurements:
 - Bottom (B) - flush with side edges of duct.
 - Sides (S) - flush with bottom section of insulation.
 - Top (T) - flush with outside edges of side sections (to shed water if necessary).
- **Using AEROFLEX adhesive best practices,** apply thin coat of adhesive to clean duct surface and cut Breathe-EZ with brush or roller and allow to tack. Do not glue edge seams yet.
- Once adhesive is ready for contact, carefully apply Breathe-EZ to duct with weighted roller to ensure complete contact.
- Ensure that edge seams are flush.

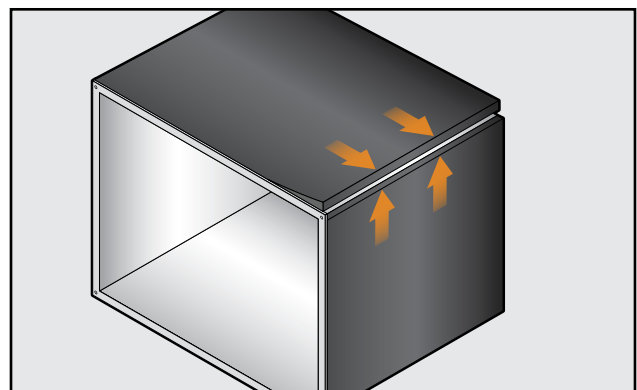
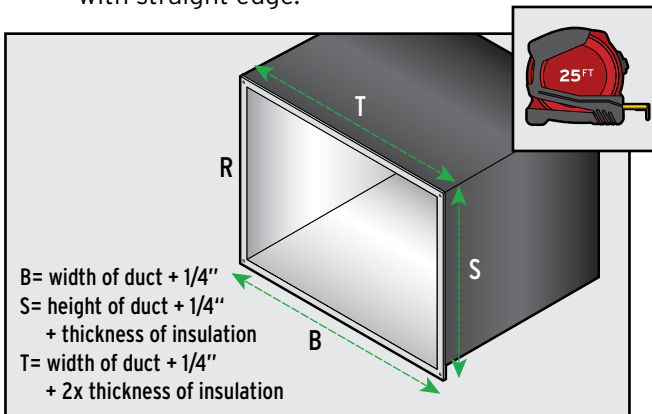

- Apply adhesive to flush edge seams and allow to tack.

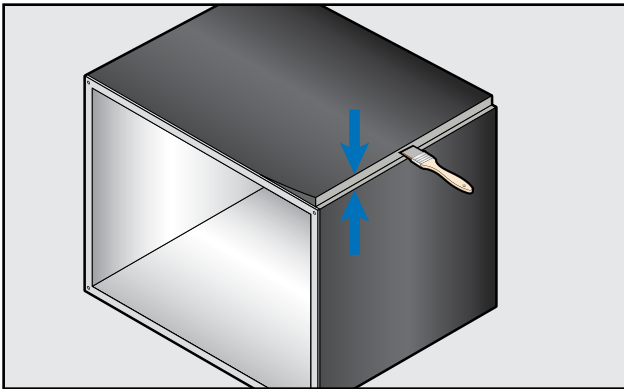

- Once adhesive is ready for contact, carefully install glued edge seams flush and with firm pressure under compression to ensure complete contact and vapor seal.

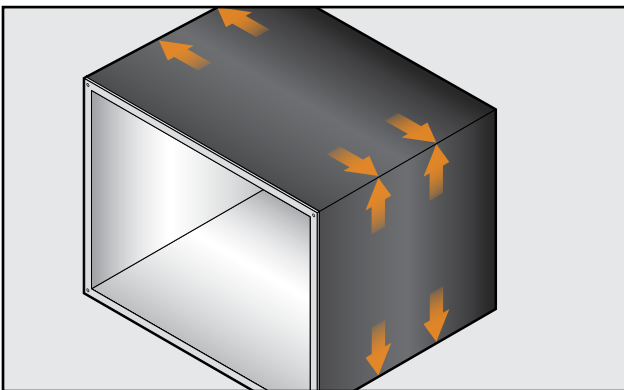

- To meet low-VOC requirements, select **AEROFLEX Breathe-EZ PSA** and **Aeroseal LVOC Black** adhesive to seal seams.
 - Optional: for interior installations, apply Protape over all glued seams.
 - Required: for exterior installations, apply 2" Protape evenly over seams followed by 2" on either side of taped seam (4" [10 cm] total taped seam width).
 - Optional (recommended): to maximize AEROFLEX life cycle for exterior applications, apply Aerocoat, Aerocoat LVOC or jacketing system for UV protection. For mechanical protection, install jacketing system specifically designed for duct insulation.

• AEROFLEX Breathe-EZ PSA



- Thoroughly clean sheet metal surfaces to receive insulation with denatured alcohol to remove dust, oil or moisture.
- **Notes:**
 - For exterior applications, horizontal rectangular ductwork must have a pitch on top side, as determined by HVAC designer, to allow for watershed to prevent ponding of water and ice.
 - When jacketing Breathe-EZ for exterior applications, confirm with jacket manufacturer recommended jacket and tape overlap (when applicable) at sealed seams.
 - For multi-layer applications, ensure that all 2nd-layer seams are staggered over 1st layer.
- Measure duct dimensions and cut Breathe-EZ with straight edge.

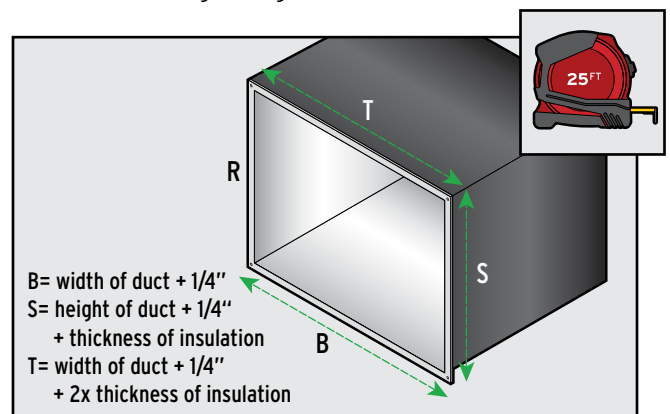

- **Note:** add 1/4" [.64 cm] to all measurements for compression-fitting seams (not stretched).

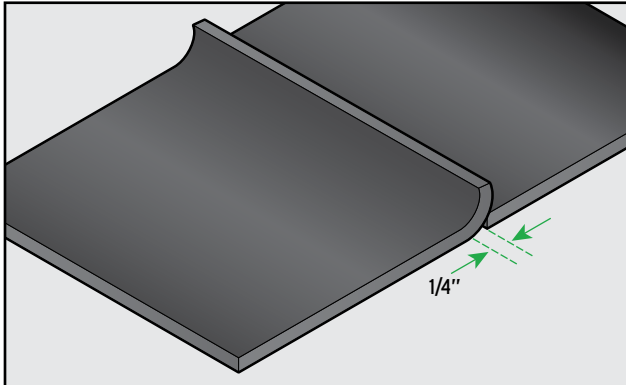

- Duct must be insulated in same sequence as measurements:
 - Bottom (B) - flush with side edges of duct.
 - Sides (S) - flush with bottom section of insulation.
 - Top (T) - flush with outside edges of side sections (to shed water if necessary).
- To remove PSA release liner, pinch corner of Breathe-EZ and peel back 1"-2" [2.5 cm - 5 cm].

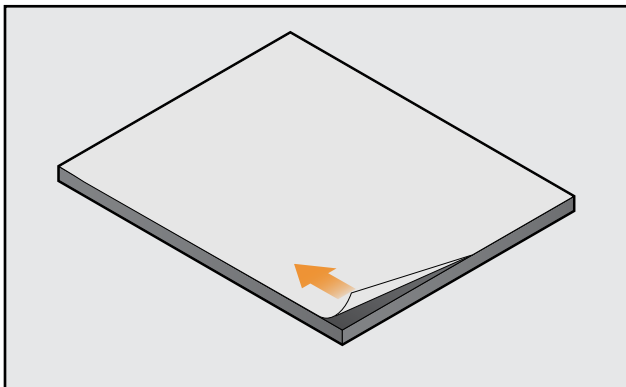

- Position and align exposed edge at termination or adjoining insulation.

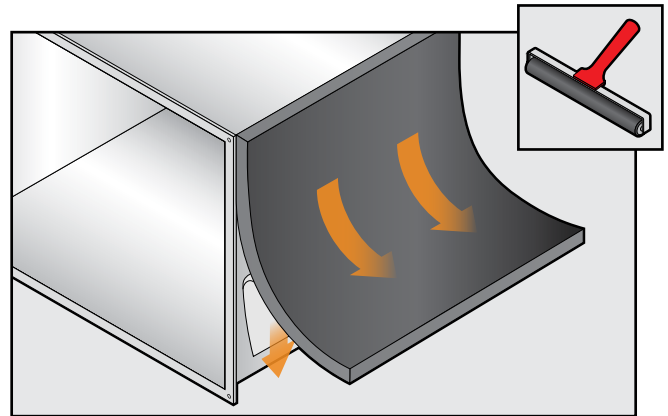

- Peel back approximately 6" - 10" [15 cm - 25 cm] of release liner and press Breathe-EZ firmly into place to activate PSA using weighted roller to ensure complete adhesion.
- Continue to end of cut roll.
- Ensure that edge seams are flush.

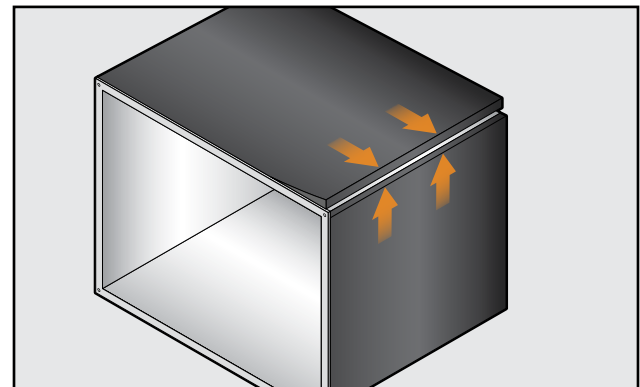

- Apply adhesive to flush edge seams and allow to tack.

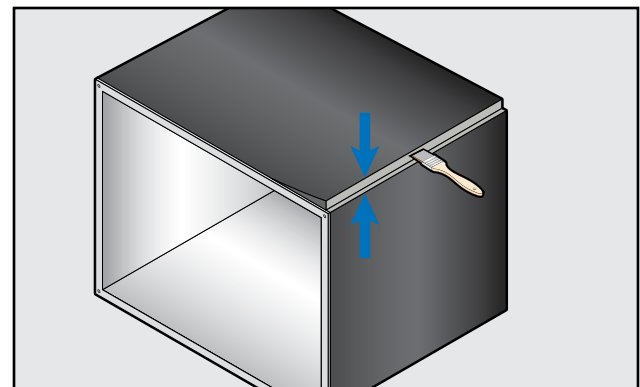

- Once adhesive is ready for contact, carefully install glued edge seams flush and with firm pressure under compression to ensure complete contact and vapor seal.

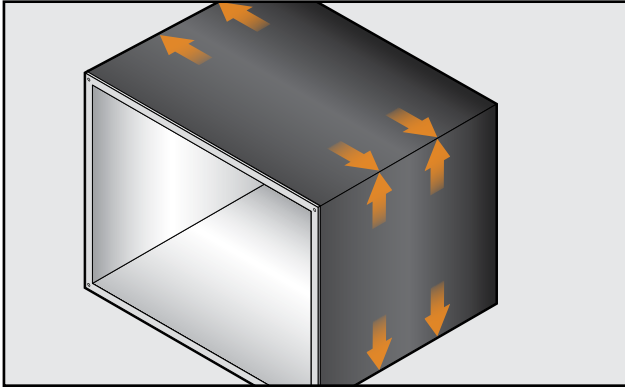

- Optional: for interior installations, apply Protape over all glued seams.
- Required: for exterior installations, apply 2" Protape evenly over seams followed by 2" on either side of taped seam (4" [10 cm] total taped seam width).
- Optional (recommended): to maximize AEROFLEX life cycle for exterior applications, apply Aerocoat, Aerocoat LVOC or jacketing system for UV protection. For mechanical protection, install jacketing system specifically designed for duct insulation.

• Duct Flanges

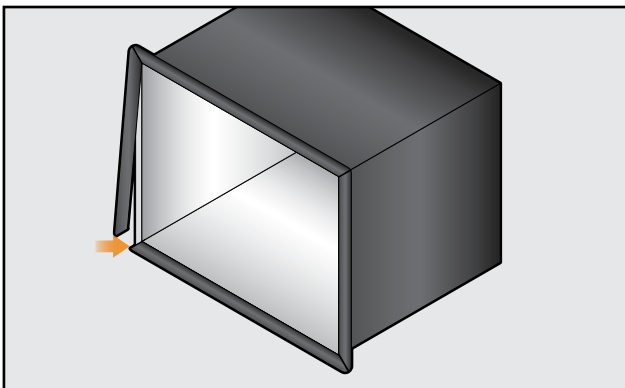

- AEROFLEX Tubes
 - Using AEROFLEX 6' [1.9 m] unslit tube of same thickness as duct wrap, slit longitudinally along entire length.

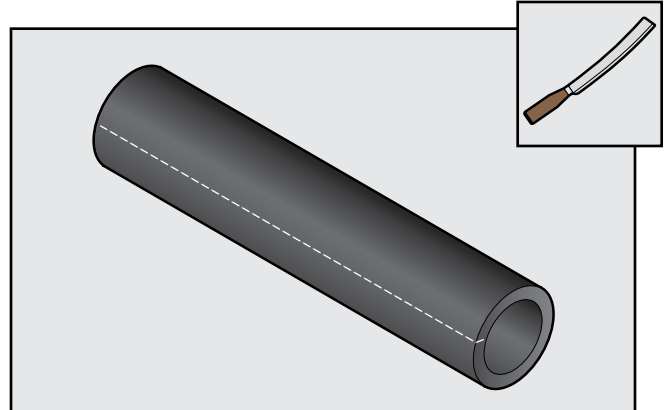

- Measure length of four duct flanges.
- Using AEROFLEX Template, cut end of slit tube at 45° angle.
- Mark duct flange length on cut tube at 45° angle.

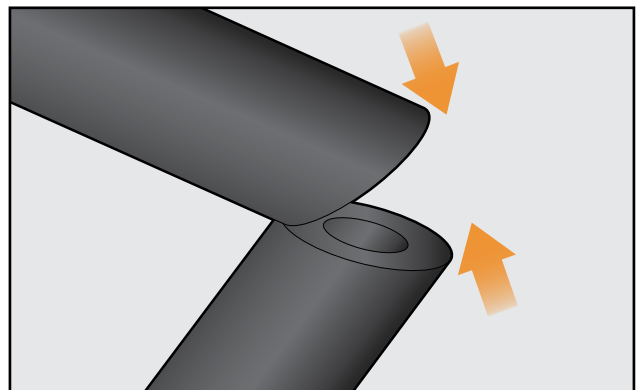

- Continue until all four (4) duct flange insulation fitting components are cut.
- Glue three (3) of the four (4) 45° seams with adhesive to create flange insulation fitting.

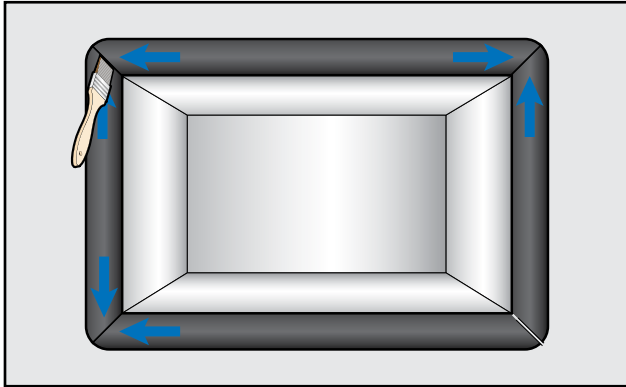

- Wrap flange insulation fitting around duct flange and glue final 45° seam.

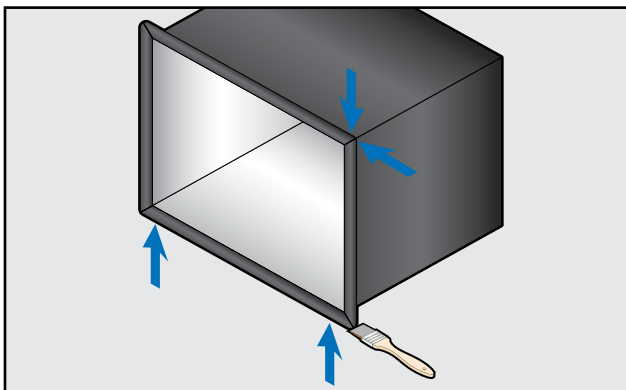

- Glue four (4) flange insulation fitting edges to duct wrap with adhesive under compression to create vapor seal.

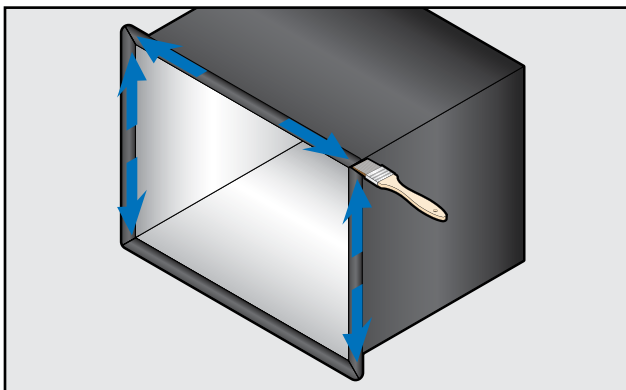

- Optional: for interior installations, apply Protape over all flange insulation fitting seams.
- Optional (recommended): to maximize AEROFLEX life cycle for exterior applications, apply Aerocoat, Aerocoat LVOC or jacketing system for UV protection. For mechanical protection, install jacketing system specifically designed for duct insulation.

• AEROFLEX Breathe-EZ Duct Insulation

- Using Breathe-EZ insulation of same height as duct flange, fabricate strips using various methods to fully insulate flange.

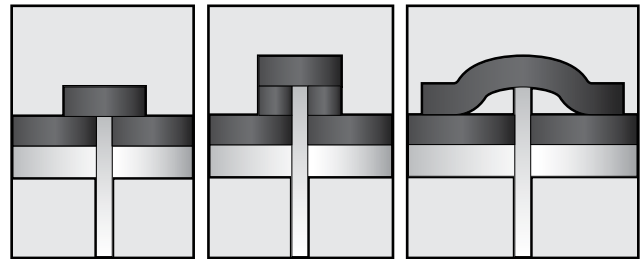

- Glue all four (4) edges of flange insulation fitting to duct wrap insulation with adhesive under compression to create vapor seal.
- Optional (recommended): to maximize AEROFLEX life cycle for exterior applications, apply Aerocoat, Aerocoat LVOC or jacketing system for UV protection. For mechanical protection, install jacketing system specifically designed for duct insulation.

DUCT LINER | ROUND SPIRAL DUCTS

- AEROFLEX Breathe-EZ is not a conformable duct liner for small duct diameters.
- If lining round spiral ducts is required, the following guidelines should be followed:
 - Limit duct lengths so center of duct can be reached with spray adhesive and pinning device.
 - Suggested duct diameter for Breathe-EZ @ 1" thick = 12", 1-1/2" thick = 14", 2" thick = 16".
 - Cut and install Breathe-EZ with friction fit.

DUCT LINER | RECTANGULAR DUCTS



- AEROFLEX Breathe-EZ Duct Insulation | AEROFLEX Adhesive



• Notes:

- Metal nosing must be installed where Breathe-EZ edges meet unlined metal and when upstream edges are exposed to air velocities > 4,000 fpm [1,219 mpm].
- Mechanical fasteners (weld pins), installed per SMACNA duct construction standards, should have beveled or cupped heads and not compress the insulation more than 1/8" [.32 cm].

- **For 1" thick Breathe-EZ, 1-1/8" pins are required.**
- **CAUTION:** Allow adhesive to flash off until dry to the touch prior to installing weld pins.
- When using an aerosolized spray contact adhesive, confirm with manufacturer that adhesive is recommended for bonding closed cell flexible elastomeric foam insulation as a duct liner to sheet metal ductwork and follow application instructions.
- If UV lights are installed inside the ductwork, Breathe-EZ should be protected with Aerocoat or Aerocoat LVOC insulation coating.
- Thoroughly clean sheet metal surfaces to receive insulation with denatured alcohol to remove dust, oil or moisture.

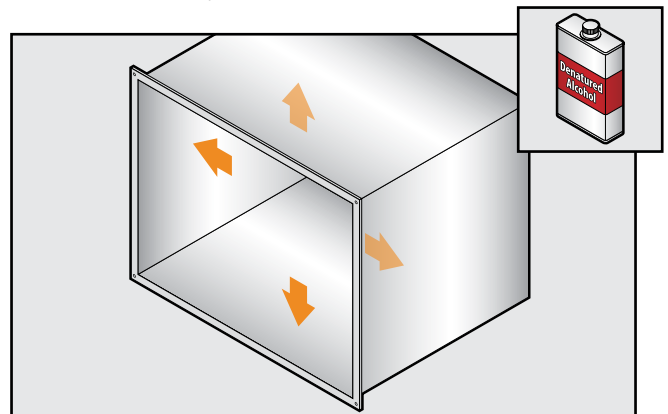

- Measure duct dimensions and cut Breathe-EZ with straight edge.

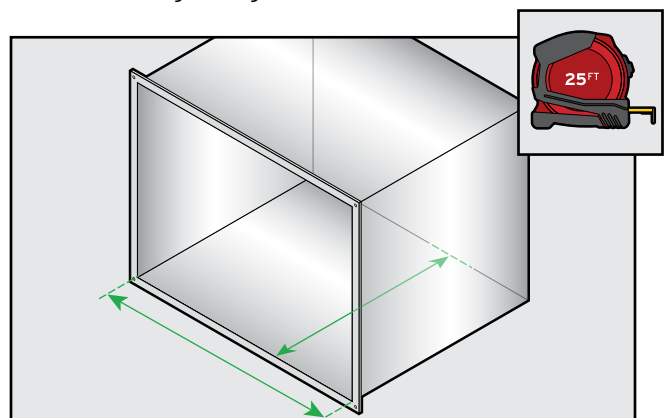

- **Note:** Add 1/4" [.64 cm] to all measurements for compression-fitting seams (not stretched, no gaps).
- Duct liner must be installed in the following sequence:
 - Top - flush with side edges of duct.

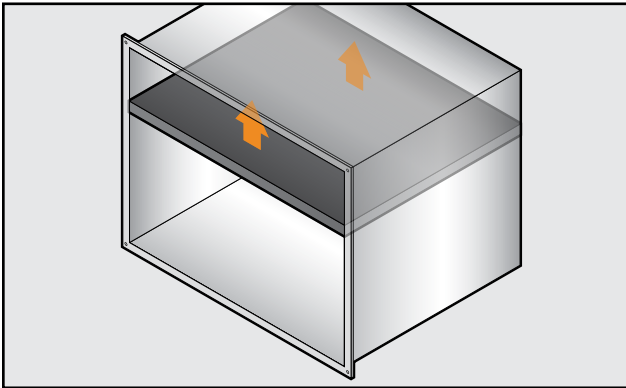

- Sides - abuts top section of insulation and bottom side of sheet metal.

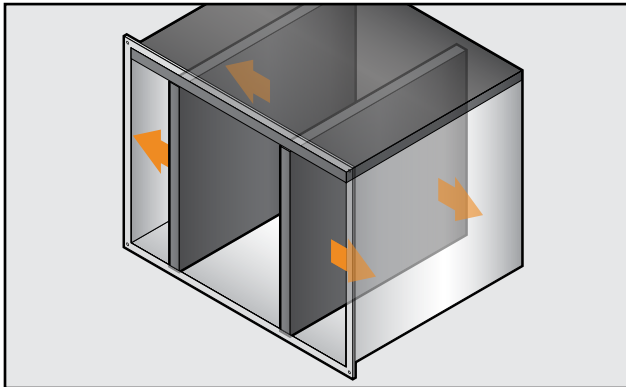

- Bottom - abuts inside edges of side sections.

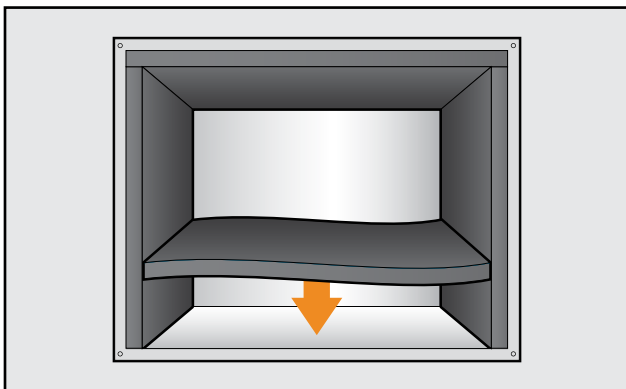

- **Using AEROFLEX adhesive best practices,** apply thin coat of adhesive to clean duct surface and Breathe-EZ achieving a minimum of 90% coverage and allow to tack.
- Once adhesive is ready for contact, carefully install cut to duct using weighted roller to ensure complete contact.

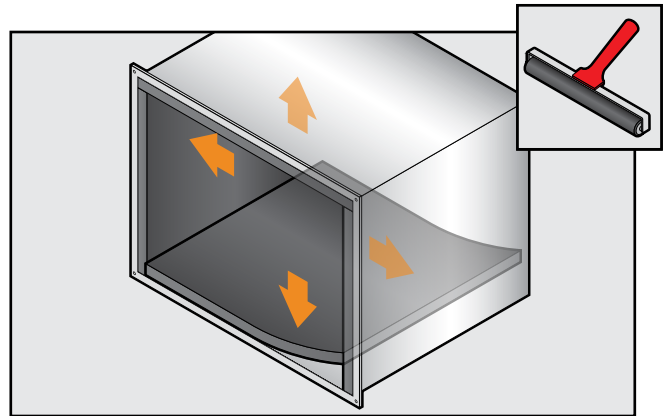

- Ensure that all four (4) inside corner edge seams fit under compression with no gaps present since it is impractical to seal them with adhesive.

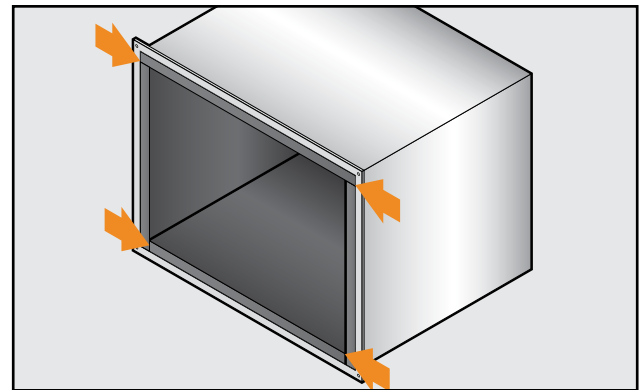

- Seal all transverse edges under compression with adhesive.

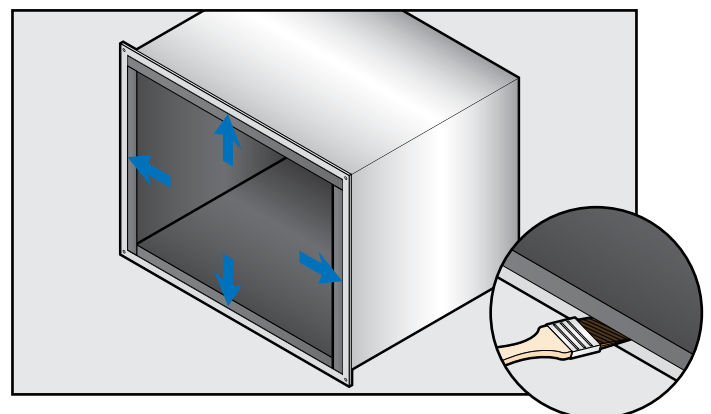

- **AEROFLEX Breathe-EZ PSA Duct Insulation**



• **Notes:**

- Metal nosing must be installed where Breathe-EZ duct liner edges meet unlined metal and when upstream edges are exposed to air velocities > 4,000 fpm [1,219 mpm].
- Mechanical fasteners (weld pins), installed per SMACNA duct construction standards, should have beveled or cupped heads and not compress the insulation more than 1/8" [.32 cm].
- **For 1" thick Breathe-EZ, 1-1/8" pins are required.**
- If UV lights are installed inside the ductwork, Breathe-EZ should be protected with Aerocoat or Aerocoat LVOC insulation coating.
- Thoroughly clean sheet metal surfaces to receive insulation with denatured alcohol to remove dust, oil or moisture.

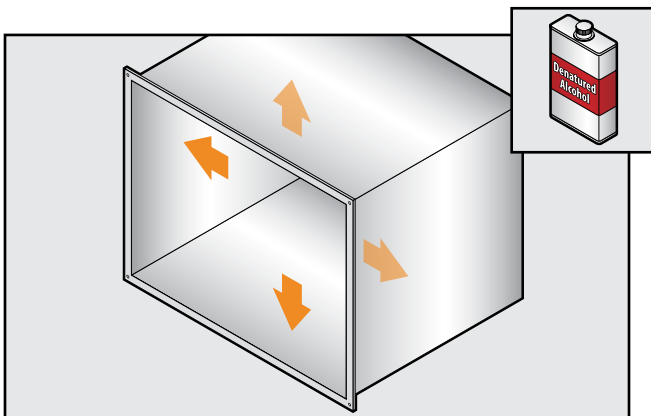

- Measure duct dimensions and cut Breathe-EZ with PSA with straight edge.

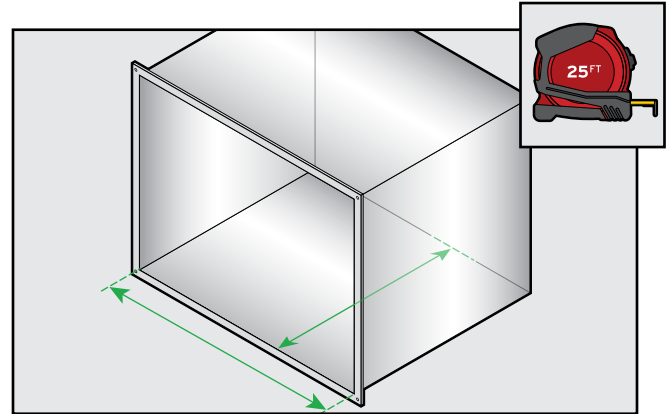

- **Note:** Add 1/4" [.64 cm] to all measurements for compression-fitting seams (not stretched).

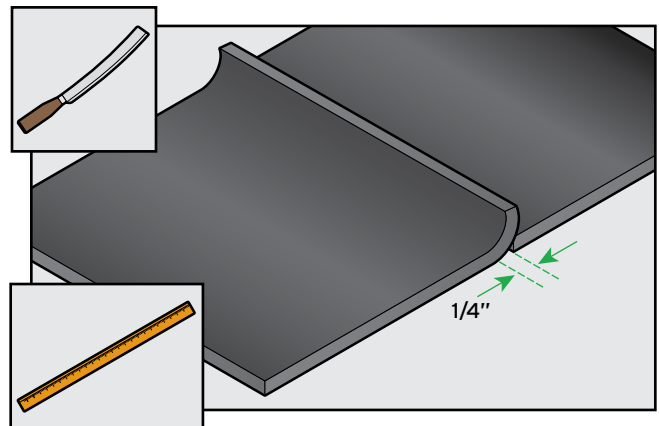

- Duct liner must be installed in the following sequence:
 - Top - flush with side edges of duct.

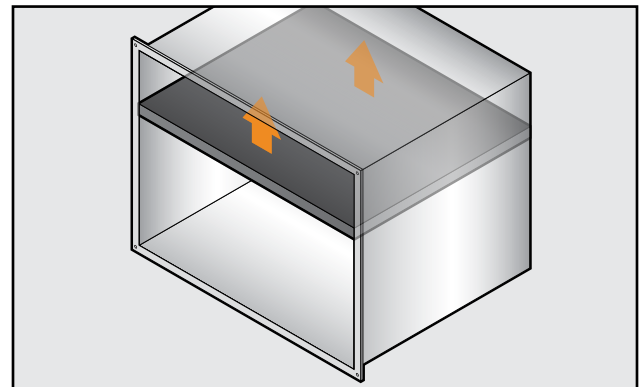

- Sides - flush with top section of insulation and bottom side of sheet metal.

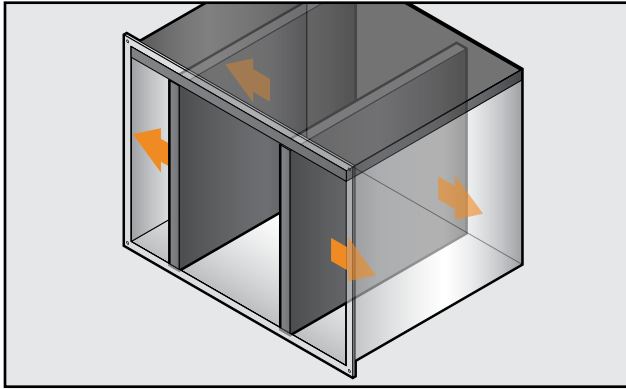

- Position and align exposed edge at termination or transverse edge.

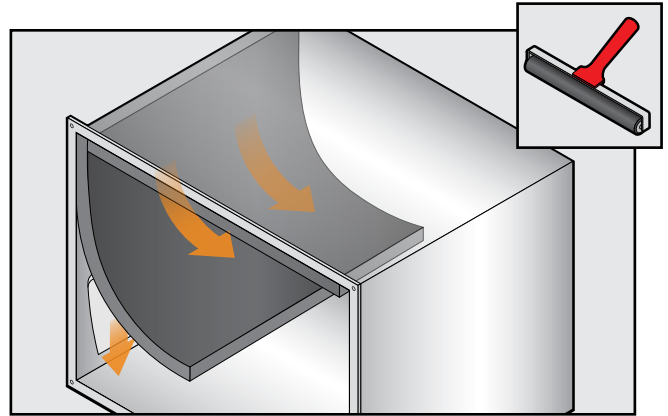

- Bottom - flush with inside edges of side sections.

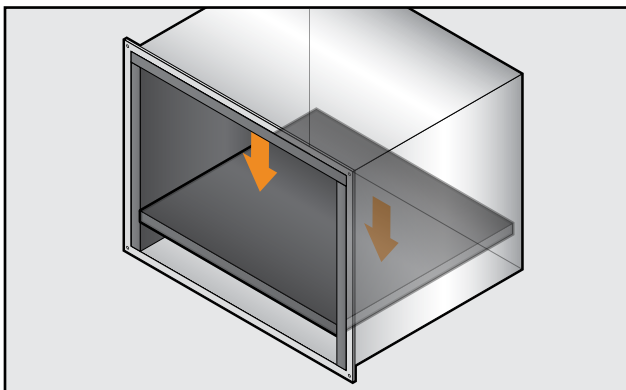

- Peel back approximately 6" - 10" [15 cm - 25 cm] of release liner and press sheet/roll firmly into place to activate PSA with weighted roller to ensure complete adhesion.
- Continue to end of cut Breathe-EZ.
- Ensure that all four (4) inside corner edge seams fit under compression with no gaps present since it is impractical to seal them with adhesive.

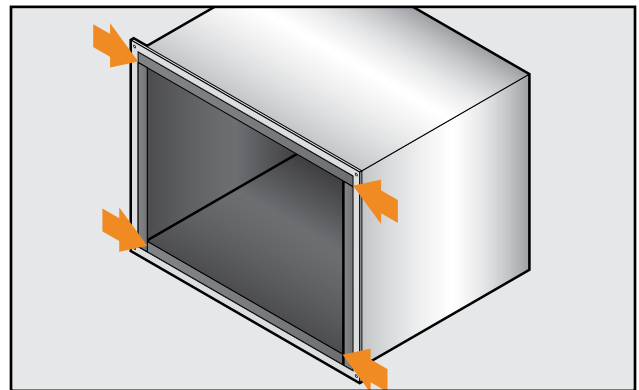

- To remove PSA release liner, pinch corner of roll and peel back 1"-2" [2.5 cm - 5 cm].

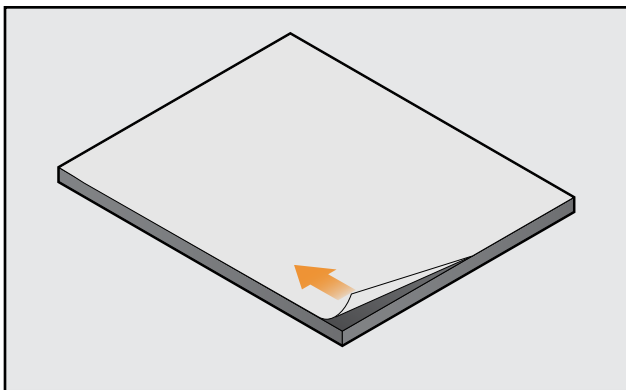

- Seal all transverse edges under compression with adhesive.

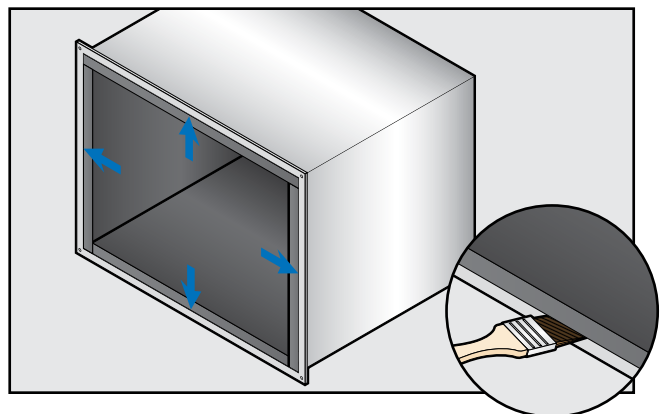

Nesting Chart (IPS) for AEROFLEX EPDM™ Pipe Insulation

Iron Pipe Size	Iron Pipe OD (in)	Layer	Insulation Thickness (in) * Does not pass ASTM E84 25/50						
			1"	1-1/2"	2"	* 2-1/2"	* 3"	* 3-1/2"	* 4"
1/2"	0.875	Inner	7/8 x 1/2	7/8 x 1/2	7/8 x 1	7/8 x 1	7/8 x 1-1/2	7/8 x 1-1/2	7/8 x 2
		Outer	1-7/8 x 1/2	1-7/8 x 1	2-7/8 x 1	2-7/8 x 1-1/2	4-1/8 x 1-1/2	4-1/8 x 2	4-1/8 x 2
3/4"	1.050	Inner	1-1/8 x 1/2	1-1/8 x 1/2	1-1/8 x 1	1-1/8 x 1	1-1/8 x 1-1/2	1-1/8 x 1-1/2	1-1/8 x 2
		Outer	2-1/8 x 1/2	2-1/8 x 1	3-1/8 x 1	3-1/8 x 1-1/2	4-1/8 x 1-1/2	4-1/8 x 2	4-1/8 x 2
1"	1.375	Inner	1-3/8 x 1/2	1-3/8 x 1/2	1-3/8 x 1	1-3/8 x 1	1-3/8 x 1-1/2	1-3/8 x 1-1/2	1-3/8 x 2
		Outer	2-3/8 x 1/2	2-3/8 x 1	3-1/2 x 1	3-1/2 x 1-1/2	4-1/2 x 1-1/2	4-1/2 x 2	5-1/2 x 2
1-1/4"	1.625	Inner	1-5/8 x 1/2	1-5/8 x 1/2	1-5/8 x 1	1-5/8 x 1	1-5/8 x 1-1/2	1-5/8 x 1-1/2	1-5/8 x 2
		Outer	2-5/8 x 1/2	2-5/8 x 1	3-5/8 x 1	3-5/8 x 1-1/2	4-1/2 x 1-1/2	4-1/2 x 2	5-1/2 x 2
1-1/2"	1.900	Inner	1-7/8 x 1/2	1-7/8 x 1/2	1-7/8 x 1	1-7/8 x 1	1-7/8 x 1-1/2	1-7/8 x 1-1/2	1-7/8 x 2
		Outer	2-7/8 x 1/2	2-7/8 x 1	4-1/8 x 1	4-1/8 x 1-1/2	5-1/2 x 1-1/2	5-1/2 x 2	6-1/8 x 2
2"	2.375	Inner	2-3/8 x 1/2	2-3/8 x 1/2	2-3/8 x 1	2-3/8 x 1	2-3/8 x 1-1/2	2-3/8 x 1-1/2	2-3/8 x 2
		Outer	3-1/2 x 1/2	3-1/2 x 1	4-1/2 x 1	4-1/2 x 1-1/2	5-1/2 x 1-1/2	5-1/2 x 2	6-5/8 x 2
2-1/2"	2.875	Inner	2-7/8 x 1/2	2-7/8 x 1/2	2-7/8 x 1	2-7/8 x 1	2-7/8 x 1-1/2	2-7/8 x 1-1/2	2-7/8 x 2
		Outer	4-1/8 x 1/2	4-1/8 x 1	5-1/8 x 1	5-1/8 x 1-1/2	6-1/8 x 1-1/2	6-1/8 x 2	SHEET
3"	3.500	Inner	3-1/2 x 1/2	3-1/2 x 1/2	3-1/2 x 1	3-1/2 x 1	3-1/2 x 1-1/2	3-1/2 x 1-1/2	3-1/2 x 2
		Outer	4-1/2 x 1/2	4-1/2 x 1	5-1/2 x 1	5-1/2 x 1-1/2	6-5/8 x 1-1/2	6-5/8 x 2	SHEET
3-1/2"	4.000	Inner	4-1/8 x 1/2	4-1/8 x 1/2	4-1/8 x 1	4-1/8 x 1	4-1/8 x 1	4-1/8 x 2	4-1/8 x 2
		Outer	5-1/8 x 1/2	5-1/8 x 1	6-1/8 x 1	6-1/8 x 1-1/2	6-1/8 x 2	SHEET	SHEET
4"	4.500	Inner	4-1/2 x 1/2	4-1/2 x 1/2	4-1/2 x 1	4-1/2 x 1	4-1/2 x 2	4-1/2 x 2	4-1/2 x 2
		Outer	5-1/2 x 1/2	5-1/2 x 1	6-5/8 x 1	6-5/8 x 1-1/2	8-5/8 x 1	SHEET	8-5/8 x 2
4-1/2"	5.000	Inner	5-1/8 x 1/2	5-1/8 x 1/2	5-1/8 x 1	5-1/8 x 1-1/2	5-1/8 x 2	5-1/8 x 2	5-1/8 x 2
		Outer	6-1/8 x 1/2	6-1/8 x 1	SHEET	SHEET	SHEET	SHEET	SHEET
5"	5.563	Inner	5-1/2 x 1/2	5-1/2 x 1/2	5-1/2 x 1	5-1/2 x 1-1/2	5-1/2 x 1-1/2	5-1/2 x 1-1/2	5-1/2 x 2
		Outer	6-5/8 x 1/2	6-5/8 x 1	SHEET	8-5/8 x 1	8-5/8 x 1-1/2	8-5/8 x 2	SHEET
6"	6.625	Inner	6-5/8 x 1/2	6-5/8 x 1/2	6-5/8 x 1	6-5/8 x 1	6-5/8 x 1	6-5/8 x 2	6-5/8 x 2
		Outer	SHEET	SHEET	8-5/8 x 1	8-5/8 x 1-1/2	8-5/8 x 2	10-3/4 x 1-1/2	10-3/4 x 2
7"	7.625	Inner	SHEET	SHEET	SHEET	SHEET	SHEET	SHEET	SHEET
		Outer	SHEET	SHEET	SHEET	SHEET	SHEET	SHEET	SHEET
8"	8.625	Inner	8-5/8 x 1/2	8-5/8 x 1/2	8-5/8 x 1	8-5/8 x 1	8-5/8 x 1	8-5/8 x 2	8-5/8 x 2
		Outer	SHEET	SHEET	10-3/4 x 1	10-3/4 x 1-1/2	10-3/4 x 2	12-3/4 x 1-1/2	12-3/4 x 2
9"	9.625	Inner	SHEET	SHEET	SHEET	SHEET	SHEET	SHEET	SHEET
		Outer	SHEET	SHEET	SHEET	SHEET	SHEET	SHEET	SHEET
10"	10.750	Inner	10-3/4 x 1/2	10-3/4 x 1/2	10-3/4 x 1	10-3/4 x 1	10-3/4 x 1-1/2	10-3/4 x 1-1/2	10-3/4 x 2
		Outer	SHEET	SHEET	12-3/4 x 1	12-3/4 x 1-1/2	14 x 1-1/2	14 x 2	SHEET
11"	11.750	Inner	SHEET	SHEET	SHEET	SHEET	SHEET	SHEET	SHEET
		Outer	SHEET	SHEET	SHEET	SHEET	SHEET	SHEET	SHEET
12"	12.750	Inner	SHEET	SHEET	12-3/4 x 1	12-3/4 x 1-1/2	12-3/4 x 1-1/2	12-3/4 x 1-1/2	12-3/4 x 2
		Outer	SHEET	SHEET	SHEET	16 x 1	16 x 1-1/2	16 x 2	SHEET
14"	14.000	Inner	SHEET	SHEET	14 x 1	14 x 1	14 x 1	14 x 2	14 x 2
		Outer	SHEET	SHEET	16 x 1	16 x 1-1/2	16 x 2	SHEET	SHEET
15"	15.000	Inner	SHEET	SHEET	SHEET	SHEET	SHEET	SHEET	SHEET
		Outer	SHEET	SHEET	SHEET	SHEET	SHEET	SHEET	SHEET
16"	16.000	Inner	SHEET	SHEET	16 x 1	16 x 1-1/2	16 x 2	16 x 2	16 x 2
		Outer	SHEET	SHEET	SHEET	SHEET	SHEET	SHEET	SHEET

Notes:

1. Combinations listed are for iron pipe only.
2. Depending on product availability, other size combinations may be possible.
3. AEROFLEX standard unslit tubes are available up to 6" IPS; AEROFLEX Self-Seal tubes are available up to 16" IPS.
4. AEROFLEX acutal tube ID's are listed.
5. Sizes are calculated using closest ID for snug fit to first layer. Depending on actual tolerance of ID and wall thickness, outer layers may fit slightly tight or loose. If 2nd layer fits too tight, use AEROFLEX Sheet or Roll.
6. Do not stretch 2nd layer. If acceptable, a tube can be installed loose over the first layer by following the AEROFLEX® Installation Guide.
7. Iron pipe sizes over 16" IPS must be insulated with AEROFLEX Sheet or Roll.
Rev 042823

TECHNICAL RESOURCES

Nesting Chart (Copper) for AEROFLEX EPDM™ Pipe Insulation

Copper Tube ID (in)	Copper Tube OD (in)	Layer	Insulation Thickness (in) * Does not pass ASTM E84 25/50						
			1"	1-1/2"	2"	* 2-1/2"	* 3"	* 3-1/2"	* 4"
1/8"	1/4"	Inner	3/8 x 1/2	3/8 x 1/2	3/8 x 1/2	3/8 x 1/2	3/8 x 1-1/2	3/8 x 1-1/2	3/8 x 2 (U)
		Outer	1-3/8 x 1/2	1-3/8 x 1	1-3/8 x 1-1/2	1-3/8 x 2	3-1/2 x 1-1/2	3-1/2 x 2	4-1/2 x 2
1/4"	3/8"	Inner	3/8 x 1/2	3/8 x 1/2	3/8 x 1/2	3/8 x 1/2	3/8 x 1-1/2	3/8 x 1-1/2	3/8 x 2 (U)
		Outer	1-3/8 x 1/2	1-3/8 x 1	1-3/8 x 1-1/2	1-3/8 x 2	3-1/2 x 1-1/2	3-1/2 x 2	4-1/2 x 2
3/8"	1/2"	Inner	1/2 x 1/2	1/2 x 1/2	1/2 x 1	1/2 x 1	1/2 x 1	1/2 x 1-1/2	1/2 x 2
		Outer	1-5/8 x 1/2	1-5/8 x 1	2-5/8 x 1	2-5/8 x 1-1/2	2-5/8 x 2	3-1/2 x 2	4-1/2 x 2
1/2"	5/8"	Inner	5/8 x 1/2	5/8 x 1/2	5/8 x 1/2	5/8 x 1/2	5/8 x 1	5/8 x 3 (U)	5/8 x 3 (U)
		Outer	1-5/8 x 1/2	1-5/8 x 1	1-5/8 x 1-1/2	1-5/8 x 2	2-5/8 x 2	6-5/8 x 1/2	6-5/8 x 1
5/8"	3/4"	Inner	3/4 x 1/2	3/4 x 1/2	3/4 x 1/2	3/4 x 1/2	3/4 x 1	3/4 x 3 (U)	3/4 x 3 (U)
		Outer	1-7/8 x 1/2	1-7/8 x 1	1-7/8 x 1-1/2	1-7/8 x 2	2-7/8 x 2	SHEET	SHEET
3/4"	7/8"	Inner	7/8 x 1/2	7/8 x 1/2	7/8 x 1/2	7/8 x 1/2	7/8 x 1	7/8 x 3 (U)	7/8 x 3 (U)
		Outer	1-7/8 x 1/2	1-7/8 x 1	1-7/8 x 1-1/2	1-7/8 x 2	2-7/8 x 2	SHEET	SHEET
1"	1-1/8"	Inner	1-1/8 x 1/2	1-1/8 x 1/2	1-1/8 x 1/2	1-1/8 x 1/2	1-1/8 x 1	1-1/8 x 1-1/2	1-1/8 x 3 (U)
		Outer	2-1/8 x 1/2	2-1/8 x 1	2-1/8 x 1-1/2	2-1/8 x 2	3-1/8 x 2	4-1/8 x 2	SHEET
1-1/4"	1-3/8"	Inner	1-3/8 x 1/2	1-3/8 x 1/2	1-3/8 x 1/2	1-3/8 x 1/2	1-3/8 x 1	1-3/8 x 2	1-3/8 x 2
		Outer	2-3/8 x 1/2	2-3/8 x 1	2-3/8 x 1-1/2	2-3/8 x 2	3-1/2 x 2	5-1/2 x 1-1/2	5-1/2 x 2
1-1/2"	1-5/8"	Inner	1-5/8 x 1/2	1-5/8 x 1/2	1-5/8 x 1/2	1-5/8 x 1/2	1-5/8 x 2	1-5/8 x 3 (U)	1-5/8 x 3 (U)
		Outer	2-5/8 x 1/2	2-5/8 x 1	2-5/8 x 1-1/2	2-5/8 x 2	SHEET	SHEET	SHEET
2"	2-1/8"	Inner	2-1/8 x 1/2	2-1/8 x 1/2	2-1/8 x 1/2	2-1/8 x 1/2	2-1/8 x 1	2-1/8 x 2	2-1/8 x 2
		Outer	3-1/8 x 1/2	3-1/8 x 1	3-1/8 x 1-1/2	3-1/8 x 2	4-1/8 x 2	6-1/8 x 1-1/2	6-1/8 x 2
2-1/2"	2 5/8"	Inner	2-5/8 x 1/2	2-5/8 x 1/2	2-5/8 x 1/2	2-5/8 x 2	2-5/8 x 2	2-5/8 x 2	2-5/8 x 2
		Outer	3-5/8 x 1/2	3-5/8 x 1	3-5/8 x 1-1/2	6-5/8 x 1/2	6-5/8 x 1	6-5/8 x 1-1/2	6-5/8 x 2
3"	3-1/8"	Inner	3-1/8 x 1/2	3-1/8 x 1/2	3-1/8 x 1/2	3-1/8 x 1/2	3-1/8 x 1-1/2	3-1/8 x 1-1/2	3-1/8 x 2
		Outer	4-1/8 x 1/2	4-1/8 x 1	4-1/8 x 1-1/2	4-1/8 x 2	6-1/8 x 1-1/2	6-1/8 x 2	SHEET
4"	3-5/8"	Inner	3-5/8 x 1/2	3-5/8 x 1	3-5/8 x 1-1/2	3-5/8 x 1-1/2	3-5/8 x 1-1/2	3-5/8 x 1-1/2	3-5/8 x 1-1/2
		Outer	SHEET	SHEET	6-5/8 x 1/2	6-5/8 x 1	6-5/8 x 1-1/2	6-5/8 x 2	SHEET
5"	4-1/8"	Inner	4-1/8 x 1/2	4-1/8 x 1/2	4-1/8 x 1	4-1/8 x 1	4-1/8 x 2	4-1/8 x 2	4-1/8 x 2
		Outer	5-1/8 x 1/2	5-1/8 x 1	6-1/8 x 1	6-1/8 x 1-1/2	SHEET	SHEET	SHEET
6"	5-1/8"	Inner	5-1/8 x 1/2	5-1/8 x 1/2	5-1/8 x 1/2	5-1/8 x 1/2	5-1/8 x 2	5-1/8 x 2	5-1/8 x 2
		Outer	6-1/8 x 1/2	6-1/8 x 1	6-1/8 x 1-1/2	6-1/8 x 2	SHEET	SHEET	SHEET

Notes:

- 1) Combinations listed are for copper tube size only.
- 2) AEROFLEX Self-Seal actual tube ID's are listed. When Self-Seal size is not available, standard unslit tube size listed (U).
- 3) AEROFLEX Self-Seal tubes are available up to 16" IPS.
- 4) AEROFLEX standard unslit tubes are available up to 6" IPS.
- 5) Depending on product availability, other size combinations may be possible.
- 6) Sizes are calculated using closest ID for snug fit to first layer. Depending on actual tolerance of ID and wall thickness, outer layers may fit slightly tight or loose. If 2nd layer fits too tight, use AEROFLEX® Sheet or Roll.
- 7) Do not stretch 2nd layer. If acceptable, a tube can be installed loose over the first layer by following the AEROFLEX® Installation Guide. Still air sealed between layers provides excellent thermal conductivity.

TECHNICAL RESOURCES

Stretch-Outs for Jacketing of AEROFLEX EPDM™ Pipe Insulation

AEROFLEX	THICKNESS						
	1/4"	3/8"	1/2"	3/4"	1"	1-1/2"	2"
Label ID	Stretch Out (in)	Stretch Out (in)	Stretch Out (in)	Stretch Out (in)	Stretch Out (in)	Stretch Out (in)	Stretch Out (in)
1/4"	2.98*	3.61*	4.24*	5.81	7.54	11.15*	N/A
3/8"	3.46*	4.02	4.65	6.22	7.95	11.56	14.86*
1/2"	3.86*	4.49	5.12	6.69	8.42	12.03	15.33
5/8"	4.27*	4.90	5.53	7.10	8.98	12.44	15.74
3/4"	4.65*	5.28	5.91	7.48	9.36	12.82	16.12
7/8"	5.00*	5.62	6.44	8.20	9.71	13.48	16.78
1-1/8"	5.78*	6.41	7.23	8.98	10.49	14.26	17.56
1-3/8"	N/A	7.35	8.36	10.18	11.44	15.21	18.50
1-5/8"	N/A	8.48	9.17	11.00	12.25	16.18	19.63
1-7/8"	N/A	9.42	10.12	11.94	13.19	17.12	20.58
2-1/8"	N/A	10.05	10.93	12.57	13.82	17.75	21.21
2-3/8"	N/A	10.84	11.72	13.35	14.61	18.54	21.99
2-5/8"	N/A	11.66	12.53	14.17	15.43	19.35	22.81
2-7/8"	N/A	12.69	13.57	15.21	16.46	20.39	23.84
3-1/8"	N/A	13.29	14.17	15.80	17.06	20.99	24.44
3-1/2"	N/A	14.73	15.80	17.25	18.50	22.43	25.89
3-5/8"	N/A	14.92	15.99	17.44	18.69	22.62	26.08
4-1/8"	N/A	16.52	17.59	19.04	20.29	24.22	27.68
4-1/2"	N/A	17.81	18.88	20.33	21.58	25.51	28.97
5-1/8"	N/A	N/A	20.80	22.24	23.50	27.43	30.88
5-1/2"	N/A	N/A	22.31	23.75	25.01	28.93	32.39
6-1/8"	N/A	N/A	24.28	25.73	26.99	30.91	34.37
6-5/8"	N/A	N/A	25.98	27.43	28.68	32.61	36.07
8-5/8"	N/A	N/A	32.26**	33.71**	34.97**	38.89**	42.35**
10-3/4"	N/A	N/A	38.92**	40.37**	41.63**	45.55**	49.01**
12-3/4"	N/A	N/A	N/A	N/A	47.91**	51.84**	55.29**
14"	N/A	N/A	N/A	N/A	51.93**	55.86**	59.31**
16"	N/A	N/A	N/A	N/A	58.21**	62.14**	65.60**

WARNING:

- Stretch-outs calculated using maximum outside diameter (OD) tolerance per ASTM C534 Type I. Actual OD may be smaller.
- This table is provided as a convenience for sizing jacketing materials. It is the responsibility of the installer to determine the correct fit of jacketing materials over AEROFLEX EPDM™ pipe insulation.

*Standard (unslit) tubes only

**Self-Seal tubes only

TECHNICAL RESOURCES

Outside Diameters for Jacketing of AEROFLEX EPDM™ Pipe Insulation

AEROFLEX	THICKNESS						
	1/4"	3/8"	1/2"	3/4"	1"	1 - 1/2"	2"
Label ID	Total OD (in)	Total OD (in)	Total OD (in)	Total OD (in)	Total OD (in)	Total OD (in)	Total OD (in)
1/4"	0.95	1.15	1.35	1.85	2.40	3.55	N/A
3/8"	1.10	1.28	1.48	1.98	2.53	3.68	N/A
1/2"	1.23	1.43	1.63	2.13	2.68	3.83	N/A
5/8"	1.36	1.56	1.76	2.26	2.86	3.96	5.01
3/4"	1.48	1.68	1.88	2.38	2.98	4.08	5.13
7/8"	1.59	1.79	2.05	2.61	3.09	4.29	5.34
1 - 1/8"	1.84	2.04	2.30	2.86	3.34	4.54	5.59
1 - 3/8"	N/A	2.34	2.66	3.24	3.64	4.84	5.89
1 - 5/8"	N/A	2.70	2.92	3.50	3.90	5.15	6.25
1 - 7/8"	N/A	3.00	3.22	3.80	4.20	5.45	6.55
2 - 1/8"	N/A	3.20	3.48	4.00	4.40	5.65	6.75
2 - 3/8"	N/A	3.45	3.73	4.25	4.65	5.90	7.00
2 - 5/8"	N/A	3.71	3.99	4.51	4.91	6.16	7.26
2 - 7/8"	N/A	4.04	4.32	4.84	5.24	6.49	7.59
3 - 1/8"	N/A	4.23	4.51	5.03	5.43	6.68	7.78
3 - 1/2"	N/A	4.69	5.03	5.49	5.89	7.14	8.24
3 - 5/8"	N/A	4.75	5.09	5.55	5.95	7.20	8.30
4 - 1/8"	N/A	5.26	5.6	6.06	6.46	7.71	8.81
4 - 1/2"	N/A	N/A	6.01	6.47	6.87	8.12	9.22
5 - 1/8"	N/A	N/A	6.62	7.08	7.48	8.73	9.83
5 - 1/2"	N/A	N/A	7.10	7.56	7.96	9.21	10.31
6 - 1/8"	N/A	N/A	7.73	8.19	8.59	9.84	10.94
6 - 5/8"	N/A	N/A	8.27	8.73	9.13	10.38	11.48
8 - 5/8"	N/A	N/A	10.27	10.73	11.13	12.38	13.48
10 - 3/4"	N/A	N/A	12.39	12.85	13.25	14.50	15.60
12 - 3/4"	N/A	N/A	N/A	N/A	15.25	16.50	17.60
14"	N/A	N/A	N/A	N/A	16.53	17.78	18.88
16"	N/A	N/A	N/A	N/A	18.53	19.78	20.88

WARNING:

- Maximum outside diameters are calculated using dimensional properties of AEROFLEX maximum wall and ID manufacturing tolerances. Actual OD may be smaller than referenced OD's.
- This table is provided as a convenience for sizing jacketing materials. It is the responsibility of the installer to determine the correct fit of jacketing materials over AEROFLEX pipe insulation.

TECHNICAL RESOURCES

Yield of AEROFLEX® Sheet & Roll Insulation on Piping

Pipe Size	Insulation Thickness (inches)	Insulation Width Pipe Circumference (inches)	Sheet Length (linear feet)	Coverage per Sheet (linear feet)	Roll Length (linear feet)	Yield per Roll (4' lengths)	Coverage per Roll (square feet)
5" IPS	1/2"	18-3/4"	3	6	70	44	176
	3/4"	19-3/4"	3	6	50	30	120
	1"	20-1/4"	3	6	35	20	80
	1-1/2"	22-1/8"	3	6	25	13	52
6" IPS	1/2"	22-3/4"	3	6	70	36	144
	3/4"	23-3/4"	3	6	50	25	100
	1"	25-1/8"	4	4	35	16	64
	1-1/2"	25-3/4"	4	4	25	11	44
8" IPS	1/2"	28-7/8"	4	4	70	29	116
	3/4"	30"	4	4	50	20	80
	1"	31"	4	4	35	13	52
	1-1/2"	33-1/8"	4	4	25	9	36
	2"	34-1/2"	4	4	18	6	24
10" IPS	1/2"	35-1/8"	4	4	70	23	92
	3/4"	37-1/4"	3	3	50	16	64
	1"	37-1/2"	3	3	35	11	44
	1-1/2"	39-1/2"	3	3	25	7	28
	2"	41-5/8"	3	3	18	5	20
12" IPS	1/2"	41-3/4"	3	3	70	20	80
	3/4"	42-5/8"	3	3	50	14	56
	1"	43-1/2"	3	3	35	9	36
	1-1/2"	46"	3	3	25	6	24
	2"	47-7/8"	3	3	18	4	16
14" IPS	1/2"	45-5/8"	3	3	70	18	72
	3/4"	46-3/8"	3	3	50	12	48
	1"	48"	3	3	35	8	32
	1-1/2"	48-7/8"	ROLL	ROLL	25	6	24
	2"	50-1/2"	ROLL	ROLL	18	4	16
16" IPS	1/2"	51-7/8"	ROLL	ROLL	70	16	64
	3/4"	52-5/8"	ROLL	ROLL	50	11	44
	1"	53-3/8"	ROLL	ROLL	35	7	28
	1-1/2"	55-1/8"	ROLL	ROLL	25	5	20
	2"	55-7/8"	ROLL	ROLL	18	3	12
18" IPS	1/2"	58-3/4"	ROLL	ROLL	70	14	56
	3/4"	59-1/4"	ROLL	ROLL	50	10	40
	1"	59-7/8"	ROLL	ROLL	35	7	28
	1-1/2"	61-1/2"	ROLL	ROLL	25	4	16
	2"	62-1/4"	ROLL	ROLL	18	3	12
20" IPS	1/2"	64-7/8"	ROLL	ROLL	70	12	48
	3/4"	65-5/8"	ROLL	ROLL	50	9	36
	1"	66-1/2"	ROLL	ROLL	35	6	24
	1-1/2"	68"	ROLL	ROLL	25	4	16
	2"	69-5/8"	ROLL	ROLL	18	3	12
24" IPS	1/2"	77-1/2"	ROLL	ROLL	70	10	40
	3/4"	78"	ROLL	ROLL	50	7	28
	1"	78-5/8"	ROLL	ROLL	35	5	20
	1-1/2"	80-3/8"	ROLL	ROLL	25	3	12
	2"	82"	ROLL	ROLL	18	2	8

TECHNICAL RESOURCES

Aeroflex USA Technical Bulletins

<https://www.aeroflexusa.com/technical-bulletins>

Insulation Thickness calculator

- Mechanical Insulation Design Guide (MIDG)
- The condensation control calculator gives you the ability to easily and efficiently calculate the correct insulation thickness for your project.
- Once the link below is clicked, scroll towards bottom of page and click on link for “Condensation Control Calculator for Horizontal Pipe.”
- <https://insulation.org/training-tools/systemdesign/>
 - Disclaimer - The reference to this mechanical insulation industry resource is provided as a service and convenience for our customers. Aeroflex USA, Inc. has no control over the content or accuracy of the information provided, nor do we guarantee the results of the thickness calculations generated by the MIDG.



EXPRESS LIMITED WARRANTY AEROFLEX® PRODUCTS

Please read the following terms and conditions (herein, the “Express Limited Warranty Information”) carefully, as such terms and conditions are affected by the installation conditions for products to be warranted. Products not specifically listed herein are not warranted. **Aeroflex USA, Inc.** (“**Seller**”) does not assume nor does it authorize any person to assume or extend on its behalf any warranty obligation or liability other than that set out in the **Express Limited Warranty** appearing below; such **Express Limited Warranty** constitutes the entire warranty obligation of Seller with respect to the following described products, which are divided into two categories: (a) Insulation Products; and (b) Tape, Adhesive, and Coating Products (the Insulation Products and the Tape, Adhesive, and Coating Products are collectively referred to herein as the “**AEROFLEX®Products**”).

Warranted Products (each a “Warranted Product”):

Insulation Products

AEROFLEX Breathe-EZ® EPDM Duct Insulation
AEROFLEX Breathe-EZ® PSA EPDM Duct Insulation
AEROFLEX EPDM™ Elastomeric Sheet and Roll Insulation
AEROFLEX EPDM™ Elastomeric Sheet and Roll Insulation with PSA
AEROFLEX EPDM™ Elastomeric Unslit Tube Insulation
AEROFLEX Self-Seal™ EPDM Elastomeric Pre-Slit Tube Insulation
AEROFLEX REF™EPDM Elastomeric Sheet and Roll Insulation
AEROFLEX REF™EPDM Elastomeric Sheet and Roll Insulation with PSA
AEROFLEX REF™EPDM Elastomeric Unslit Tube Insulation
AEROFLEX REF™Self-Seal EPDM Elastomeric Pre-Slit Tube Insulation
AEROFLEX REF™White/Gray EPDM Elastomeric Unslit Tube Insulation
AEROFLEX REF™White/Gray Self-Seal EPDM Elastomeric Pre-Slit Tube Insulation
AEROFLEX®White/Gray EPDM Elastomeric Unslit Tube Insulation
AEROFLEX®White/Gray Self-Seal EPDM Elastomeric Pre-Slit Tube Insulation
AEROFLEX®COIL PACK EPDM Elastomeric Unslit Tube Insulation
AEROFLEX EPDM™ CONTINUOUS EPDM Elastomeric Unslit Tube Insulation
AEROFLEX AEROFIT™EPDM Elastomeric Fittings (Elbows, 45s, P-Traps, Tees, Mechanical Grooved)
AEROFLEX AEROFIT™REF™EPDM Elastomeric Fittings (Elbows, 45s, P-Traps, Tees, Mechanical Grooved)
AEROFLEX AEROFIT™White/Gray Elastomeric Fittings (Elbows, 45s, P-Traps, Tees)
AEROFLEX AEROFIT™EPDM Elastomeric Fittings with SaniGuard™(Elbows, Tees)
AEROFLEX AEROFIX®Insulated Pipe Supports

Tape, Adhesive and Coating Products

AEROFLEX®Adhesive - trade name AEROSEAL
AEROFLEX®Adhesive (LVOC) - trade name AEROSEAL LVOC™BLACK
AEROFLEX®Adhesive - trade name REF 1520™
AEROFLEX®Coating - trade name AEROCOAT®
AEROFLEX®Coating (LVOC) - trade name AEROCOAT LVOC®
AEROFLEX®Tape (EPDM) - trade name PROTAPÉ®
AEROFLEX®Tape (Foam) - trade name AEROTAPÉ™
AEROFLEX®Tape (Cork) - trade name EVERSEAL™

Express Limited Warranty

The AEROFLEX® Products (listed above) are warranted to the original purchaser (“Buyer”), provided that the AEROFLEX® Products are installed and used in accordance with the Seller’s written installation instructions, to be free from original defects in materials or factory workmanship, or excessive degradation as a result thereof, for: (a) one (1) year from the date of installation for Insulation Products (except for obvious defects in materials or factory workmanship appearing at the time of installation, of which Buyer must notify Seller in writing within 30 days of the date of installation in order to make a warranty claim hereunder – See Procedure to Submit a Warranty Claim, below; and (b) one (1) year from the date of purchase for Tape, Adhesive and Coating Products (except for obvious defects in materials or factory workmanship appearing at the time of purchase, of which Buyer must notify Seller in writing within 30 days of the date of purchase in order to make a warranty claim hereunder – See Procedure to Submit a Warranty Claim, below). This Express Limited Warranty is limited as stated in this section captioned Express Limited Warranty, is subject to further conditions (the “Warranty Conditions”) and limitations (the “Warranty Limitations”) appearing below in this Express Limited Warranty Information and provides solely the remedy (the “Exclusive Remedy for Valid Warranty Claim”) to the Buyer as listed below.

THIS EXPRESS LIMITED WARRANTY CONSTITUTES THE ENTIRE OBLIGATION OF SELLER AND THERE ARE NO OTHER WARRANTIES, EXPRESS OR IMPLIED, INCLUDING ANY IMPLIED WARRANTY OF MERCHANTABILITY, WARRANTY OF FITNESS FOR ANY PURPOSE WHATSOEVER OR WARRANTY OF FITNESS FOR A PARTICULAR PURPOSE; SELLER HEREBY DISCLAIMS ALL IMPLIED WARRANTIES OF ANY TYPE OR SORT, INCLUDING WITHOUT LIMITATION: (1) THE IMPLIED WARRANTY OF MERCHANTABILITY, (2) THE IMPLIED WARRANTY OF FITNESS FOR ANY PURPOSE WHATSOEVER AND (3) THE IMPLIED WARRANTY OF FITNESS FOR A PARTICULAR PURPOSE. LIABILITY IS LIMITED TO THAT SET FORTH BELOW AND SELLER SHALL IN NO EVENT BE LIABLE TO BUYER OR TO ANY THIRD PARTY CLAIMING THROUGH BUYER, FOR ANY INSTALLATION OR REMOVAL COST OR FOR INCIDENTAL, CONSEQUENTIAL OR SPECIAL DAMAGES (INCLUDING WITHOUT LIMITATION, LOSS OF PROPERTY, PERSONAL INJURY, LOSS OF BUSINESS, LOSS OF PROFITS, OR ECONOMIC LOSSES) NOR FOR PUNITIVE, STATUTORY, OR EXEMPLARY DAMAGES, WHETHER IN NEGLIGENCE, WARRANTY, STRICT LIABILITY OR OTHERWISE.

This Express Limited Warranty shall not be modified, enlarged, expanded upon or affected in any way by verbal commentary or non-written installation instructions or other advice by any person or entity, regardless of the existence of a relationship of any type or sort between such person or entity and Seller; site specific and/or installation conditions are not the responsibility of Seller or its representatives to address or provide advice and no verbal advice by Seller or its representative concerning such matters shall constitute a warranty by Seller or alter the terms and conditions of the Express Limited Warranty as set out in this Express Limited Warranty Information. Seller makes no warranty, expressed or implied, with regard to the end-product manufactured by Buyer. Buyer, by purchasing the AEROFLEX® Products, agrees that Buyer will not alter, amend or add to Seller’s Express Limited Warranty. If Buyer desires to offer additional warranties or make any representation on its own, such warranties and/or representations will clearly state that they are Buyer’s additional warranties and not those of Seller.

Warranty Limitations

The AEROFLEX® Products are manufactured and warranted for their thermal insulation performance hereunder solely for use under normal conditions. Abnormal Conditions include exposure to certain chemical vapors, petroleum-based substances, other substances and compounds not compatible with EPDM rubber products, INCLUDING WITHOUT LIMITATION, petroleum oil and petroleum solvents such as Benzene, Gasoline, Kerosene, Octane, Toluene and Butyl Acetate and the vapors of the same. Damage to the AEROFLEX® Products which may occur from fire, accident or any form of abuse, or exposure to Abnormal Conditions is not covered by this warranty. While exposure to ultraviolet light due to outdoor use is not considered Abnormal Conditions for purposes of this Express Limited Warranty, cosmetic damage caused by outdoor use without additional weather protective coatings or coverings is not covered by this Express Limited Warranty. Cosmetic damage due to uncovered or uncoated AEROFLEX® Product exposed to ultraviolet light for purposes of this warranty is considered any damage which does not affect the thermal insulative properties of AEROFLEX® Products. All AEROFLEX® Products, including AeroFit™ insulation fittings, used outdoors must have AEROFLEX® Protape® EPDM rubber seam sealing tape applied to and covering all product seams, circumferential joints and termination points to provide a vapor seal. If exposed or installed subject to Abnormal Conditions, the product should be removed immediately and replaced once the conditions of installation are normal or with products more suitable to general ambient conditions of the installation or installation site. The growth of mold is not covered by this warranty nor is damage arising from the growth of mold the responsibility of Seller. All AEROFLEX® Products should be maintained to avoid excessive dirt or dust buildup, or the presence of excessive moisture, that would provide a medium for microbial growth on the AEROFLEX® Products.

REV. 12.9.24

Warranty Conditions

The above described **AEROFLEX® Products** each must be installed in accordance with Seller's written installation instructions for that product in effect at the time of installation and in accordance with best industry practice. Prior to installation, the insulation product must be kept clean and dry and not subject to Abnormal Conditions. Installation of the **AEROFLEX® Products** shall be installed when the ambient temperature is between 40°F (4°C) and 100°F (38°C) to allow AEROFLEX® PSA insulation products and adhesives to properly tack and bond. The **Express Limited Warranty** is void if improper installation practices or unapproved installation products are used. This **Express Limited Warranty** does not extend to any component of the insulation system other than the specific **AEROFLEX® Products** identified herein above, such as, but not limited to, adhesives other than AEROFLEX® adhesives, pinning devices, tapes other than Protape® or Aertape™, or any other accessory used in the installation of the **AEROFLEX® Products**.

Exclusive Remedy for Valid Warranty Claim

Subject to confirmation by Seller of the failure of any one or more of the **AEROFLEX® Products** to which the above **Express Limited Warranty** is to be applied, Seller will deliver, at Seller's expense, F.O.B. to the place of installation, new product, of the same or similar type and grade, in an amount equal to that which is determined to be defective. The foregoing is the EXCLUSIVE remedy against Seller upon a valid warranty claim hereunder. No other remedy (including, but not limited to, incidental or consequential damages for lost profits, lost sales, injury to person or property, or any other incidental or consequential loss) shall be available to the Buyer or to any other person, firm or entity.

Procedure to Submit a Warranty Claim

The Buyer must notify Aeroflex USA, Inc. of any product failure covered by this **Express Limited Warranty** within 30 days of first observation of failure by writing to the following address: Aeroflex USA, Inc., 232 Industrial Park Road, Sweetwater, TN 37874, or call us at 866.237.6235. Reference to Aeroflex USA, Inc. in this section shall mean, for the United States, Aeroflex USA, Inc. 232 Industrial Park Road, Sweetwater, TN 37874.

State Law

The **Express Limited Warranty** provided above gives you specific legal rights and you may also have other rights, which vary from state to state. Some jurisdictions do not allow exclusion or limitation of incidental or consequential damages or limitations on how long an implied warranty lasts, so the limitation or exclusion herein may not apply to you.

Warranty Information Complete. This Express Limited Warranty Information and the **Express Limited Warranty** contained herein is the complete and final expression of the Seller's warranty obligations with respect to the **AEROFLEX® Products** listed herein. All other prior or contemporaneous communications with regard to warranty obligations of Seller for the **AEROFLEX® Products**, regardless of whether in writing or otherwise, are merged into this Express Limited Warranty Information and this Express Limited Warranty Information shall not be modified except in a writing signed by Seller.

